

THE NEW



STANDARD

2024 HARDSCAPES PACKAGING and SPECIFICATIONS GUIDE

ROCHESTER

concrete products

A close-up, slightly textured image of the American flag, showing the stars and stripes in a draped, wavy pattern. The colors are rich and slightly muted, giving it a vintage or weathered appearance.

WE ARE FAMILY-OWNED, BORN
IN THE MIDWEST, AND MADE IN THE USA.

Rochester Concrete Products is a third-generation, family-owned manufacturer of mortarless concrete products dating back to 1914. We have consistently produced an extensive line of innovative hardscapes and building products that pass rigid quality control requirements – meeting or exceeding ASTM standards for strength, durability and freeze/thaw.



Corporate Office: 7200 Broadway Ave. N., Rochester, MN 55906 • Phone (507) 288-8850 • rochesterpc.com



THE NEW STANDARD

In 2024, with the addition of our newest plant in Jordan, MN, we look to take the next step and set a **NEW STANDARD** for the hardscape manufacturing industry with...

MIND-BLOWING COLOR

Hardscape colors are born from state-of-the-art Chroma Coloring system. These pavers are the result of high-quality materials and precision manufacturing.

CONSISTENT PRODUCT

Precise, computerized controls throughout the manufacturing process and robust inspection ensure you get the same color, same surface and same edge detail — every time.

UNMATCHED QUALITY

North America's most advanced paver production facility with manufacturing systems and quality controls like no other.

INNOVATION

As technologies and hardscape trends change, we're continually bringing new and innovative products, colors, shapes and sizes to the market.

PRODUCT AVAILABILITY

Our technology and facilities investments dramatically increase production capacity and on-hand inventory.

INDEX

PAVERS/SLABS/TILES

6 x 12 Accent Pavers	14
American Brick Paver	13
Antique Travertine Tiles	8
Barn Plank Tiles	8
Barrington & Minnetonka Pavers	12
Broadmour Pavers	11
Bullnose Paver	33
Contours Paver/Slabs	10
Colonial Pavers	15
Daltile Porcelain Pavers	20
GeoCeramica Porcelain+Paver (NEW)	7
Holland Pavers	16
Lamont Pavers	15
Mezzano and Serano Pavers	12
Silhouette Paver/Slabs (NEW)	10
Slate Tiles	8
Tahoe and Reno Pavers	14
Titan XL Paver (NEW)	11

PERMEABLE PAVERS

Cobble Stone Paver	13
Holland-Eco Pavers	16
Pacific-Eco Paver	17

RETAINING WALLS

Barn Plank Garden Wall	26
Classic 6 and 8, Classic 8 DOT Walls and Caps	22
Classic Colonial 6 Wall	23
Classic Colonial 8 Wall	27
Contemporary Wall	26
Cottage Stone Wall	26
Lakeland and Riverland Walls	25
Olympic Wall	23
Premier Series Walls (NEW)	24
Recon Wall	28
Rosetta Walls	29
StoneHedge	27
Vintage 6 Walls	25

STEPS/CAPS/EDGING

Barn Plank Step	31
Bullnose Paver	33
Chiseled Caps and Tops	31
Chisled Steps	31
Edgers	33
Grand Step	31
Stepping Stones	31
Retaining Wall Cap Blocks	30

OUTDOOR LIVING KITS

Contemporary Kits	42
Fireplace Kits	36
Fire Ring / Pits & Accessories	38
Grand Island Bar Series	40
Kitchen Cabinet Kits	44
Necessaries	36
Seatwall / Pillar Kits	39
Summerset Sizzler Pro Grills	45
Table, Waterfall and Woodbox/Stand Kits	39

ACCESSORIES / MISC.

Adhesive (Super-Stik)	32
Alliance Gator Sand/Sealers, ect.	34
Geo-Grid	32
Sleeve-It	32
Snap Edge	32

REFERENCE

Accenting and Border Paver Patterns	18-19
Calculators (Adhesive, Paver and Wall Materials)	48
Chroma Color / Chroma Shield	6
General Terms, Conditions and Policies	49/50
Open Graded Base Construction	8
Warranty	51

FREIGHT DETAILS

The following items can stack on top of other pallets but CANNOT be stacked upon due to pallet size and/or position of product on pallet:

- Antique Travertine Tiles
- Barn Plank Tiles and Garden Wall
- Slate Landscape Tiles
- Fire Ring Cap
- Cottage Stone Retaining Wall
- Stepping Stones

LOADING NOTES:

- Grand Fire Ring Kits can stack three high
- For LTL purposes, each "spot" cannot weigh over 3,000 lbs. stacked
- All pallet weights include 50 lbs. for pallet

FREIGHT RATES: Whether shipping LTL or full loads, dispatchers will find the most competitive freight rate available. Do you need a few pallets to complete a job but can't wait for a full truckload order? Dispatchers will work to get what you need shipped quickly via LTL carrier. LTL shipments less than 15,000 lbs. and 10 pallets are shipped at current rates throughout the Midwest at 1-3 day delivery.

NOTE: The information presented here has been prepared for the benefit of customers interested in Rochester Concrete Products, it was reviewed carefully prior to publication. Rochester Concrete Products assumes no liability for its accuracy or completeness. Final determination of the suitability of any information or material for the use contemplated, or for its manner of use, is the sole responsibility of the user. Not all products available in all areas. Product availability and specifications subject to change without notice.

Refer to actual product samples when making color selection.
Product dimensions given are nominal in inches, weights in pounds.

STAFF DIRECTORY

SALES

DAKOTAS / SW. & N. MINNESOTA

Glen Nevala Phone: 612-702-4115
glen.nevala@rochesterpc.com

IOWA

Jimmy Six Phone: (641) 485-4802
jimmy.six@rochesterpc.com

ILLINOIS / INDIANA

Kurt Glave (METRO & INDIANA) Phone: 847-401-3741
kurt.glave@rochesterpc.com

Crystal Novy (N. METRO & S. ILL) Phone: 630-400-4988
crystal@rochesterpc.com

MINNESOTA

Keith Ehmke (W. METRO) Phone: (262) 339-6981
keith.ehmke@rochesterpc.com

Scott Gengler (SE. MN & E. METRO) Phone: 507-269-6982
scott.gengler@rochesterpc.com

Joe Dubois (METRO) Phone: (651) 425-0606
joe.dubois@rochesterpc.com

WISCONSIN

Chad Miller (MADISON) Phone: 262-303-1099
chad.miller@rochesterpc.com

Daniel Kozak (MILWAUKEE) Phone: (262) 283-3168
daniel.kozak@rochesterpc.com

John Sheahan (N. WISC) Phone: 507-279-2950
john.sheahan@rochesterpc.com

NATIONAL ACCOUNTS

Jeff Anderson Phone: (512) 571-6402
jeff.anderson@rochesterpc.com

COMMERCIAL ACCOUNTS

Jim Weidner Phone: 507-951-4374
jweidner@moderra.com

DISPATCH

JORDAN, MN

Mark Straub Phone: 952-492-3636
mark.straub@rochesterpc.com

Becky Myre Phone: 952-492-3636
becky.myre@rochesterpc.com

ROCHESTER, MN

Jaime Martinez Phone: 507-424-4693
jaime.martinez@rochesterpc.com

THORP, WI

Tanya Kapfer Phone: 715-669-5552
tanya.kapfer@rochesterpc.com

BEAVER DAM, WI

Chery Justmann Phone: 920-386-3104
chery.justmann@rochesterpc.com

Linda Baker Phone: 920-386-3105
linda.baker@rochesterpc.com

MANUFACTURING

CORP. OFFICE/ROCHESTER PRODUCTION

7200 Broadway Ave. N, Rochester, MN 55906
Phone: 507-288-8850
Fax: 507-535-1487

BEAVER DAM PRODUCTION

W6558 Hwy 33, Juneau, WI 53039
Phone: 920-386-3333
Fax: 920-386-4612

JORDAN PRODUCTION

3535 Bluff Drive, Jordan, MN 55352
Phone: 952-492-3636

THORP PRODUCTION

N14665 Dickerson Ave., Thorp, WI 54771
Phone: 715-669-5552

SUPPORT

Crystal Mathews (Kit Warranties & Samples)

Phone: 507-535-1482
crystal.mathews@glsindustries.net

Kevin Mensink (VP Marketing)

Phone: 651-346-9778
kevin.mensink@glsindustries.net

David Spies (Marketing Support)

Phone: 507-271-2247
david.spies@glsindustries.net

Jessica Spading (Marketing Support)

Phone: 507-535-3509
jessica.spading@glsindustries.net

Justin Rueth (Web Marketing)

Phone: 507-535-3524
justin.rueth@glsindustries.net

Kim Schumacher (Acct's Receivable, Block and Paver Warranties)

Phone: 507-535-1493
kim.schumacher@glsindustries.net

WEB PAGE:

<https://rochesterpc.com>

ON-LINE REQUEST:

<https://rochesterpc.com/contact>

ON-LINE CALCULATOR:

<https://rochesterpc.com/calculator>

2024 NEW PRODUCTS:

<https://rochesterpc.com/new-in-2024>

Follow us on:



Corporate Office:
7200 Broadway Ave. N., Rochester, MN 55906
Phone: (507) 288-8850
Fax: (507) 535-1487
www.rochesterpc.com

Chroma Coloring System... a New Standard for vibrancy and consistency in paver color.

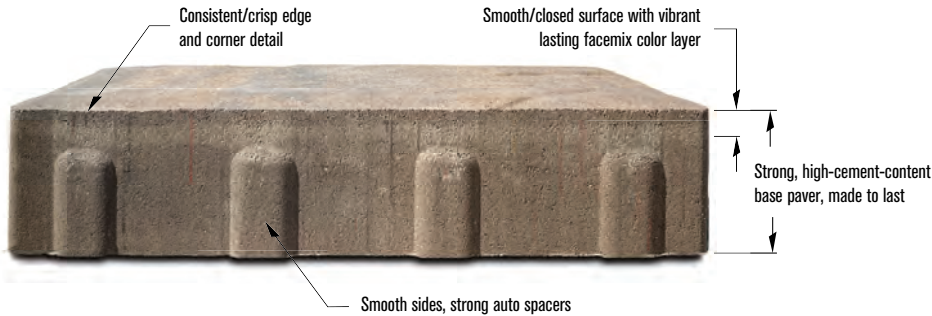

This advanced manufacturing technology provides rich and vibrant colors across all of our most popular products; Reno/Tahoe, Serano/Mezzano, Barrington/Minnetonka and our NEW Silhouette/Contours pavers. Chroma Coloring also ensures consistent colors from batch to batch – pavers ordered in August will have the same consistent and vibrant color as pavers ordered in May.

All pavers except Lamont, Holland-Eco and Pacific-Eco will now have Chroma Color (facemix) coloring.

Chroma Shield protected pavers stand up to the damaging effects of time and Mother Nature.



Chroma Shield manufactured pavers are highly resistant to fading and to the harmful effects of salt, chemical and acid rain exposure. Chroma Shield also provides some protection against stains and rust marks.

WHAT IS CHROMA SHIELD?

The Chroma Shield manufacturing process is a series of chemical reactions between the paver and the Chroma Shield solution. As pavers are demolded, a proprietary aqueous-based solution is sprayed on the surface causing a chemical/molecular reaction that creates the Chroma Shield protective layer. This new protective compound penetrates into the surface of the paver three to five millimeters deep and can only be removed with heavy abrasion/wear.

CHROMA SHIELD PAVERS ARE:

- Fade Resistant
- Acid Rain Resistant
- Spalling Resistant
- Stain Resistant
- Salt Resistant
- Inhibits Efflo and Poly Haze

YEARS LATER, CHROMA SHIELD PAVERS REMAIN EXTREMELY FADE RESISTANT.



GeoCeramica® – The best of both worlds!

GeoCeramica® combines the low-maintenance and modern aesthetic of porcelain tile with the ease of installation of concrete pavers. GeoCeramica binds a 1cm porcelain tile to a concrete paver base using a proprietary Aquaferm binding agent.

Durable and Low Maintenance:

For decades, professionals have valued the beauty and durability of porcelain tile. Easy to clean, stain and scratch resistant, and slip resistance make GeoCeramica a very attractive choice for any outdoor kitchen, rooftop, patio or pool deck application.

Easy to Install:

GeoCeramica installs just like a traditional paver over a open-graded base, Alliance Gator Base or densely-grade base – saving you time and money compared to overlay installation. GeoCeramica pavers are manufactured with a 3mm auto spacer, joints are easily filed with Alliance Gators' G2 Gator Maxx/Super Sand or Nitro Joint Sand. Use Xtreme Edge or Mini-Pro for edging restraint.

These 24 x 24 x 1.6" H pavers can be cut with a water-cooled cut-off saw using a non-segmented diamond blade. Use a roller compactor when compacting.

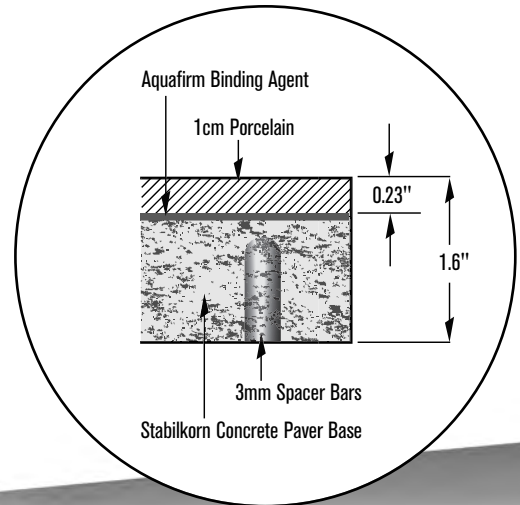

GEOCERAMICA PORCELAIN + PAVER



Surface and Edges:

- Smooth, 1cm porcelain tile bonded to a concrete paver base
- 3mm auto-spacer
- Micro-beveled tile edges, grey concrete paver base

Colors: Taupe, Smoke, Pearle, Sable

Ordering / Installation:

- Available by pallet or layer
- Suitable for paths, patios, pool decks, raised decking
- Install on open-graded base, Alliance Gator Base or densely-graded base
- Use extreme care during install to prevent edge damage
- Use Alliance Gator G2 Gator Maxx/Super Sand or Nitro joint sands and Xtreme Edge or Mini-Pro for edging restraint
- Use roller compactor or buffer pad when compacting



Dimensions	Face Area	Weight	Units/Layer	Layers	Units/Pallet	Pallet Weight
24 x 24 x 1.6" H	4 sq. ft.	70 lbs.	2	14	28 (112 sq. ft.)	1,950 lbs.

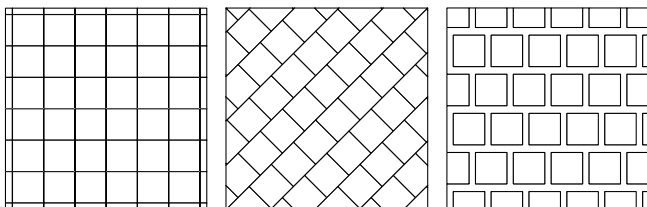

BARN PLANK LANDSCAPE TILES

Surface and Edges:

- Multiple faces, deep, authentic splits and detailed grain top and sides
- Mastered off a 17th century Swiss Barn
- Strong and durable 10,000 psi wet cast concrete



Colors: Mahogany or Weathered Grey



Ordering / Installation:

- Palletized by size, CANNOT be double stacked
- To calculate pieces divide total sq. ft. by 5.20
- Available by piece
- Suitable for paths, patios, pool decks, caps and overlays
- Gap tiles a minimum of 1/4"
- Use roller compactor or buffer pad when compacting

Size	Dimensions	Face Area	Weight	Units/pallet	Pallet Weight
Small	15.50 x 9.75 x 2" H	1.05 sq. ft.	24 lbs.	40 (42 sq. ft.)	1,010 lbs.
Medium	23.37 x 9.75 x 2" H	1.59 sq. ft.	33 lbs.	20 (31.80 sq. ft.)	710 lbs.
Large	35 x 9.75 x 2" H	2.37 sq. ft.	52 lbs.	20 (47.40 sq. ft.)	1,090 lbs.

Dimensions shown are nominal. Pallet square footage is accurate, layers and bands square footages have been rounded to nearest whole number.

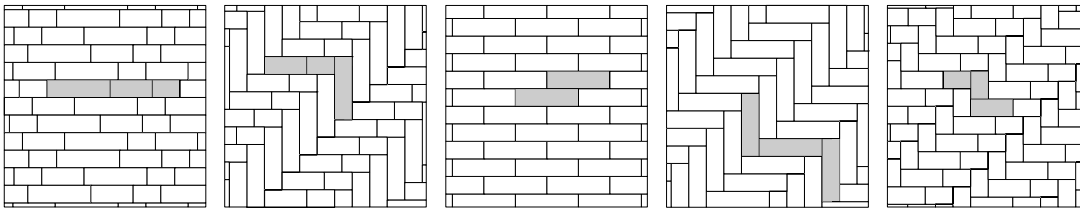

Pattern 1
Small = 20.9%
Medium = 31.63%
Large = 47.34%

Pattern 2
Small = 20.9%
Medium = 31.63%
Large = 47.34%

Pattern 3
Large = 100%

Pattern 4
Large = 100%

Pattern 5
Small = 57%
Medium = 43%

BUILD FAST AND EFFICIENTLY BY USING OPEN GRADED BASE MATERIAL AND LARGE FORMAT PAVERS

Open graded paver base construction is wet-weather friendly, costs less than conventional base and can save as much as 35 labor hours per week. In six months, you could gain as much as 840 labor hours.

Choose large format pavers and install more jobs. See the time study comparison at: www.rochestercp.com/efficiency

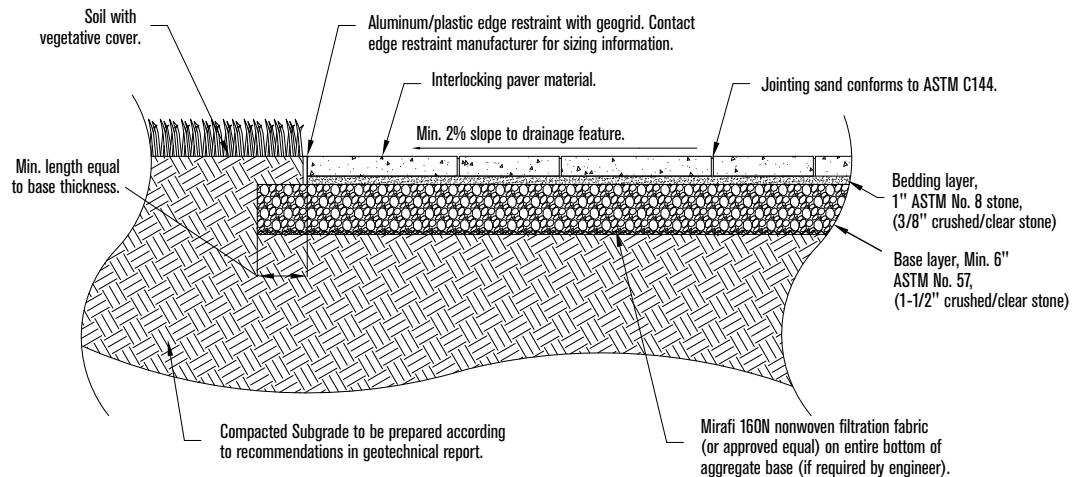

Design Notes:

1. Cross-section shown as suitable for sidewalks and patios.
2. Depth of aggregate base subject to site specific conditions such as soil conditions, groundwater levels, climate conditions, etc.
3. Depending on the permeability of subgrade soils, drain pipes should be placed within the aggregate base. Drainage needs should be verified with the geotechnical engineer. Drain pipes must be available to daylight via gravity flow to the surface or be connected to a catch basin.
4. Jointing sand that conforms to a ASTM C144 may be used in pedestrian applications. Contact your local sales representative.

SLATE LANDSCAPE TILES

Surface and Edges:

- Four sizes with 23 unique faces, detailed slate top, chiseled sides
- Strong and durable 10,000 psi wet cast concrete
- Unique 24" x 36" slab



Colors: Bluestone or Cascade

Ordering / Installation:

- Palletized by size, CANNOT be double stacked
- Available in partial pallets
- Suitable for paths, patios, pool decks, caps and overlays
- Gap tiles a minimum of 1/4", use roller compactor or buffer pad when compacting.

Size	Dimensions	Face Area	Weight	Units/pallet	Pallet Weight
Small	12 x 12 x 1-3/4" H	1 sq. ft.	18 lbs.	44 (44 sq. ft.)	840 lbs.
Medium	24 x 12 x 1-3/4" H	2 sq. ft.	35 lbs.	22 (44 sq. ft.)	930 lbs.
Large	24 x 24 x 1-3/4" H	4 sq. ft.	67 lbs.	22 (88 sq. ft.)	1,524 lbs.
XL (not shown)	24 x 36 x 1-3/4" H	6 sq. ft.	104 lbs.	16 (96 sq. ft.)	1,714 lbs.

Dimensions shown are nominal. Pallet square footage is accurate, layers and bands square footages have been rounded to nearest whole number.

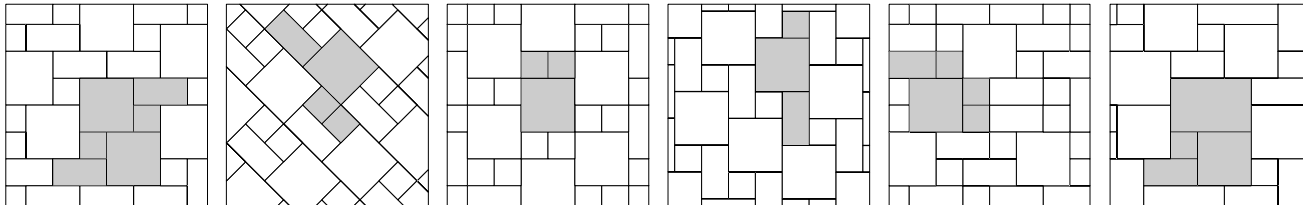

Pattern 1
Small = 14.2%
Medium = 28.5%
Large = 57.1%

Pattern 2
Small = 28.5%
Medium = 28.5%
Large = 57.1%

Pattern 3
Small = 33.3%
Large = 66.6%

Pattern 4
Small = 14.2%
Medium = 28.5%
Large = 57.1%

Pattern 5
Small = 33.3%
Medium = 22.2%
Large = 44.4%

Pattern 6
Small = 7.7%
Medium = 15.38%
Large = 30.7%
XL = 46.15%

ANTIQUE TRAVERTINE LANDSCAPE TILES

Surface and Edges:

- Three sizes w/multiple unique faces, detailed travertine top and sides, smooth honed surfaces
- Strong and durable 10,000 psi wet cast concrete



Colors: Ivory or Natural

Ordering / Installation

- Palletized by size, CANNOT be double stacked
- Available in partial pallets
- Suitable for paths, patios, pool decks and overlays
- Gap tiles a minimum of 1/4", use roller compactor or buffer pad when compacting.

Size	Dimensions	Face Area	Weight	Units/pallet	Pallet Weight
Small	12 x 24 x 2" H	2 sq. ft.	46 lbs.	20 (40 sq. ft.)	970 lbs.
Medium	18 x 24 x 2" H	3 sq. ft.	70 lbs.	18 (54 sq. ft.)	1,310 lbs.
Large	24 x 24 x 2" H	4 sq. ft.	88 lbs.	18 (72 sq. ft.)	1,634 lbs.
Bbullnose coping	24 x 12 x 2" H	2 sq. ft.	43 lbs.	20 (40 sq. ft.)	910 lbs.

Dimensions shown are nominal. Pallet square footage is accurate, layers and bands square footages have been rounded to nearest whole number.

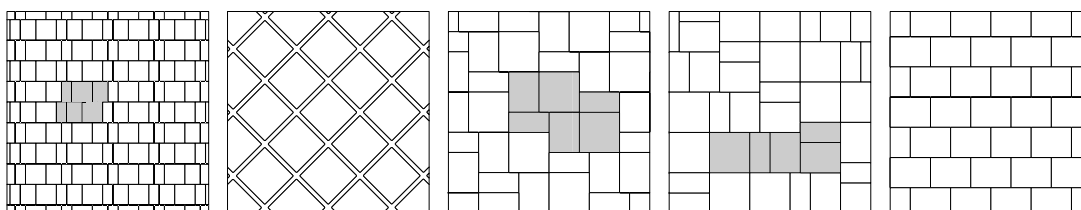

Pattern 1
Small = 22.2%
Medium = 33.3%
Large = 44.4%

Pattern 2
Large = 100%

Pattern 3
Small = 22.2%
Medium = 33.3%
Large = 44.4%

Pattern 4
Small = 28.5%
Medium = 33.3%
Large = 42.8%

Pattern 5
Medium = 100%

SILHOUETTE AND CONTOURS PAVERS



Surface and Edges:

- Contours; textured surface, straight/chamfered edge detail, small auto-spacer
- Silhouette; smooth surface, straight/chamfered edge detail, small auto spacer
- Whispers Technology creates multi-angled color graining mimicking nat. stone
- Chroma Color produced; vibrant facemix layer
- Chroma Shield protected against fading, staining, wear

Colors: Beige, Flint, Mist

Ordering / Installation:

- Three-piece, one-pallet systems, available by pallet or layer
- Suitable for paths, patios, pool decks, vehicular
- Use 6 x 12 Accent, American Brick, Colonial or Cobble Stone pavers for borders and insets
- Use roller compactor or buffer pad when compacting



CONTOURS
Textured Surface



SILHOUETTE
Smooth Surface



Size	Dimensions	Face Area	Units/Layer	Layers	Units/Pallet	Pallet Weight
Small	10 x 5 x 2-3/8" H	0.35 sq. ft.	4			
Medium	10 x 10 x 2-3/8" H	0.7 sq. ft.	4	10 (8.17 sq. ft.)	120 (81.77 sq. ft.)	2,260 lbs.
Large	15 x 10 x 2-3/8" H	1.04 sq. ft.	4			

Dimensions shown are nominal. Pallet square footage is accurate, layers and bands square footages have been rounded to nearest whole number.

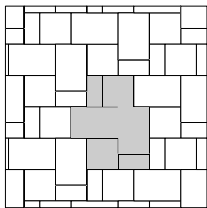

Pattern 1
Small = 16%
Medium = 33%
Large = 50%

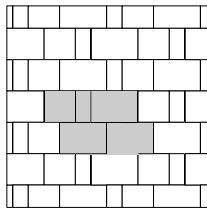

Pattern 2
Small = 16%
Medium = 33%
Large = 50%

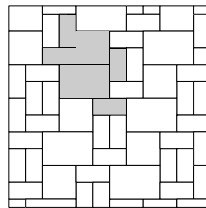

Pattern 3
Small = 44.4%
Medium = 22.2%
Large = 33.3%

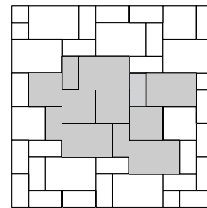

Pattern 4
Small = 18%
Medium = 27.2%
Large = 45.5%

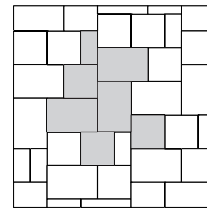

Pattern 5
Small = 6.2%
Medium = 37.5%
Large = 56.2%

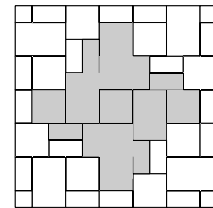

Pattern 6
Small = 16.6%
Medium = 33.3%
Large = 50%

SILHOUETTE XL AND CONTOURS XL SLABS



Surface and Edges:

- Contours; textured surface, straight/chamfered edge detail, small auto-spacer
- Silhouette; smooth surface, straight/chamfered edge detail, small auto spacer
- Chroma Color produced; vibrant facemix layer
- Chroma Shield protected against fading, staining, wear
- Whispers finishing creates multi-angled color and textured surfaces

Colors: Beige, Flint, Mist

Ordering / Installation:

- Three-piece, one-pallet systems, available by pallet or layer
- Suitable for paths, patios, pool decks
- Use 6 x 12 Accent, American Brick, Colonial or Cobble Stone pavers for borders and insets
- Use roller compactor or buffer pad when compacting



CONTOURS XL
Textured Surface



SILHOUETTE XL
Smooth Surface



Size	Dimensions	Face Area	Units/Layer	Layers	Units/Pallet	Pallet Weight
XL Small	12 x 18 x 2-3/8" H	1.5 sq. ft.	1			
XL Medium	18 x 18 x 2-3/8" H	2.25 sq. ft.	1	10 (8.00 sq. ft.)	30 (80.0 sq. ft.)	2,230 lbs.1
XL Large	30 x 18 x 2-3/8" H	3.75 sq. ft.	1			

Dimensions shown are nominal. Pallet square footage is accurate, layers and bands square footages have been rounded to nearest whole number.

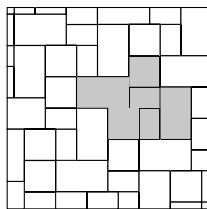

Pattern 1
XL Small = 20%
XL Medium = 30%
XL Large = 50%

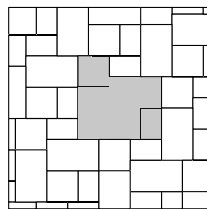

Pattern 2
XL Small = 11.20%
XL Medium = 33.3%
XL Large = 55.5%

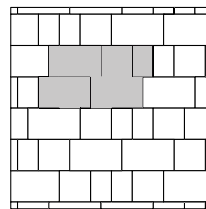

Pattern 3
XL Small = 20%
XL Medium = 30%
XL Large = 50%

BROADMOUR PAVERS/SLAB

Surface and Edges:

- Smooth surface, straight/chamfered edge, radius corners, small auto spacer
- Chroma Color produced; vibrant facemix layer
- Chroma Shield protected against fading, staining, wear

Colors: Cascade, Glacier Creek, Natural, Onyx

Ordering / Installation:

- Palletized by size, available by pallet or layer
- Suitable for paths, patios, pool decks
- Use 6 x 12 Accent, American Brick, Cobble Stone or Colonial pavers for borders and insets
- Use roller compactor or buffer pad when compacting



Size	Dimensions	Face Area	Weight	Units/Layer	Layers	Units/Pallet	Pallet Weight
Small Rectangle	6 x 12 x 2-3/8" H	0.5 sq. ft.	15.65 lbs.	24	6 (12 sq. ft.)	144 (72 sq. ft.)	2,304 lbs.
Large Rectangle	24 x 12 x 2-3/8" H	2 sq. ft.	59 lbs.	6	8 (12 sq. ft.)	48 (96 sq. ft.)	2,880 lbs.
Square	24 x 24 x 2-3/8" H	4 sq. ft.	113.5 lbs.	2	10 (8 sq. ft.)	20 (80 sq. ft.)	2,320 lbs.

Dimensions shown are nominal. Pallet square footage is accurate, layers and bands square footages have been rounded to nearest whole number.

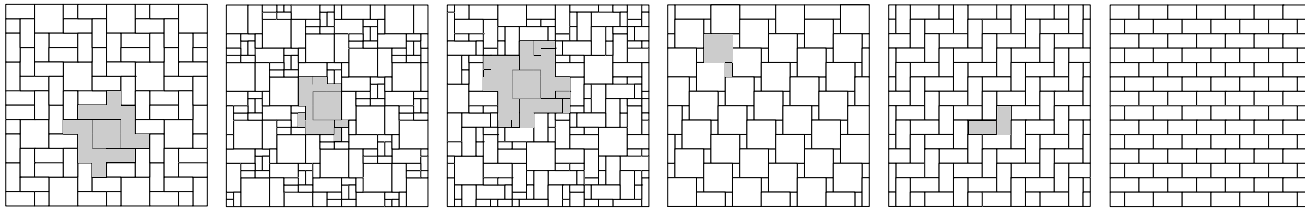

Pattern 1
Large Rectangle = 80%
Square = 20%

Pattern 2
Small Rectangle = 20.9%
Large Rectangle = 31.6%
Square = 47.4%

Pattern 3
Small Rectangle = 23%
Large Rectangle = 61.5%
Square = 15.2%

Pattern 4
Small Rectangle = 11.1%
Square = 88.9%

Pattern 5
Herringbone; rectangles

Pattern 6
Running Bond; rectangles

TITAN XL SLAB



Surface and Edges:

- Smooth surface, straight/chamfered edge, radius corners, small auto spacer
- Chroma Color produced; vibrant facemix layer
- Chroma Shield protected against fading, staining, wear

Colors: Beechwood, Cascade, Glacier Creek, Santa Fe

Ordering / Installation:

- Available by pallet or layer
- Suitable for paths, patios, pool decks
- Lifting device recommended
- Use 6 x 12 Accent, American Brick, Cobble Stone or Colonial pavers for borders and insets
- Use roller compactor or buffer pad when compacting



Size	Dimensions	Face Area	Weight	Units/Layer	Layers	Units/Pallet	Pallet Weight
Titan XL	24 x 36 x 2-3/8" H	5.7 sq. ft.	153 lbs.	2	8 (11.35 sq. ft.)	16 (90.8 sq. ft.)	2,500 lbs.

Dimensions shown are nominal. Pallet square footage is accurate, layers and bands square footages have been rounded to nearest whole number.

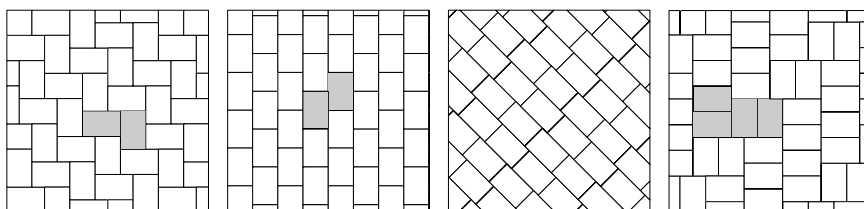

MINNETONKA AND BARRINGTON PAVERS

Surface and Edges:

- Minnetonka; textured surface, irregular/chamfered edge, radius corners, small auto-spacer
- Barrington; smooth surface, straight/chamfered edge, radius corners, small auto spacer
- Chroma Color produced; vibrant facemix layer
- Chroma Shield protected against fading, staining, wear

Colors: Beechwood, Cascade, Glacier Creek, Santa Fe

Ordering / Installation:

- Three-piece, one-pallet systems, available by pallet or layer
- Suitable for paths, patios, pool decks
- Use 6 x 12 Accent, American Brick, Cobble Stone or Colonial pavers for borders and insets
- Use roller compactor or buffer pad when compacting



MINNETONKA = Textured Surface/Irregular Edge

BARRINGTON = Smooth Surface/Straight Edge



Size	Dimensions	Face Area	Weight	Units/Layer	Layers	Units/Pallet	Pallet Weight
Small	8 x 16 x 2-3/8" H	0.89 sq. ft.	24.5 lbs	2			
Medium	16 x 16 x 2-3/8" H	1.78 sq. ft.	49 lbs.	2	10 (10.2 sq. ft.)	20 (102 sq. ft.)	3,000 lbs.
Large	16 x 24 x 2-3/8" H	2.67 sq. ft.	73.5 lbs.	2			

Dimensions shown are nominal. Pallet square footage is accurate, layers and bands square footages have been rounded to nearest whole number.

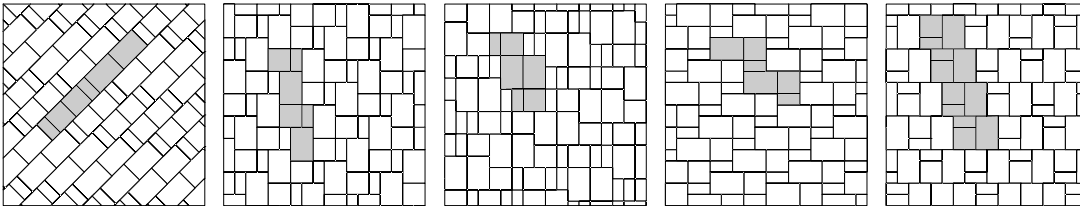

Pattern 1
One full layer

Pattern 2
One full layer

Pattern 3
One full layer

Pattern 4
One full layer

Pattern 5
Two full layers

MEZZANO AND SERANO PAVERS

Surface and Edges:

- Mezzano; textured surface, irregular/chamfered edge, radius corners, small auto-spacer
- Serano; smooth surface, straight/chamfered edge, radius corners, small auto spacer
- Chroma Color produced; vibrant facemix layer
- Chroma Shield protected against fading, staining, wear

Colors: Beechwood, Cascade, Glacier Creek, Santa Fe

Ordering / Installation:

- Three-piece, one-pallet systems, available by pallet or layer
- Suitable for paths, patios, pool decks
- Use 6 x 12 Accent, American Brick, Cobble Stone or Colonial pavers for borders and insets
- Use roller compactor or buffer pad when compacting



MEZZANO = Textured Surface/Irregular Edge

SERANO = Smooth Surface/Straight Edge



Size	Dimensions	Face Area	Weight	Units/Layer	Layers	Units/Pallet	Pallet Weight
Small	6 x 6 x 2-3/8" H	0.23 sq. ft.	6 lbs.	6			
Medium	6 x 12 x 2-3/8" H	0.46 sq. ft.	13 lbs.	6	10 (9.7 sq. ft.)	180 (97 sq. ft.)	2,685 lbs.
Large	12 x 12 x 2-3/8" H	0.92 sq. ft.	25 lbs.	6			

Dimensions shown are nominal. Pallet square footage is accurate, layers and bands square footages have been rounded to nearest whole number.

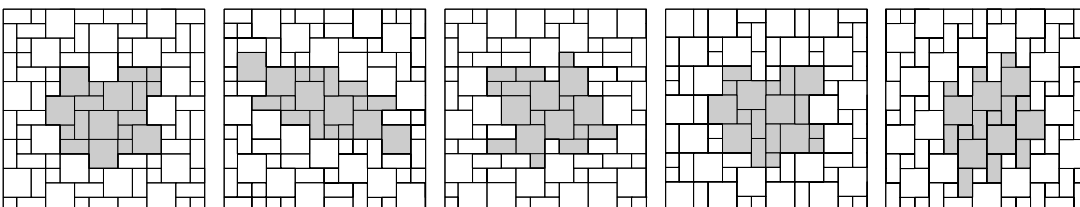

Pattern 1
One full layer

Pattern 2
One full layer

Pattern 3
One full layer

Pattern 4
One full layer

Pattern 5
One full layer

COBBLE STONE PERMEABLE PAVER

Surface and Edges:

- Smooth/embossed top, radius edge/corners, large auto-spacer (high flow-rate, eco/permeable)
- Chroma Color produced; vibrant facemix layer

Colors: Beechwood, Moonlight Grey

Ordering / Installation

- Four-piece, one-pallet system, available by pallet or layer
- Suitable for paths, patios, pool decks, vehicular
- Use roller compactor or buffer pad when compacting



Size	Dimensions	Face Area	Units/Layer	Layers	Units/Pallet	Pallet Weight
Small	7 x 6 x 2-3/8" H	0.29 sq. ft.	8			
Medium	9 x 6 x 2-3/8" H	0.36 sq. ft.	8	8 (12.33 sq. ft.)	192 (98.7 sq. ft.)	2,550 lbs.
Large	10 x 6 x 2-3/8" H	0.42 sq. ft.	8			
X Large	12 x 6 x 2-3/8" H	0.48 sq. ft.	8			

Dimensions shown are nominal. Pallet square footage is accurate, layers and bands square footages have been rounded to nearest whole number.

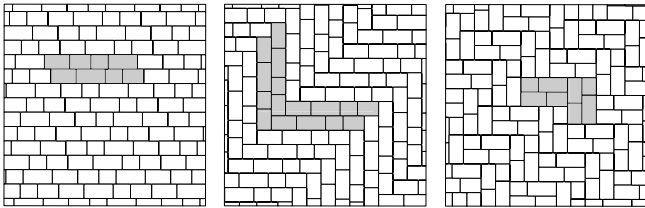

AMERICAN BRICK PAVER

Surface and Edges:

- Multiple faces, smooth/embossed top, radius edge/corners, NO auto-spacer
- Chroma Color produced; vibrant facemix layer
- Chroma Shield protected against fading, staining, wear

Colors: Brown, Buff, Onyx

Ordering / Installation:

- One size, available by pallet or layer
- Designed for borders, accents and insets
- Use roller compactor or buffer pad when compacting



Size	Dimensions	Face Area	Weight	Units/Layer	Layers	Units/Pallet	Pallet Weight
One Size	8 x 2.5 x 2-3/8" H	0.14 sq. ft.	3 lbs.	60	10 (8.4 sq. ft.)	600 (84 sq. ft.)	1,800 lbs.

Dimensions shown are nominal. Pallet square footage is accurate, layers and bands square footages have been rounded to nearest whole number.

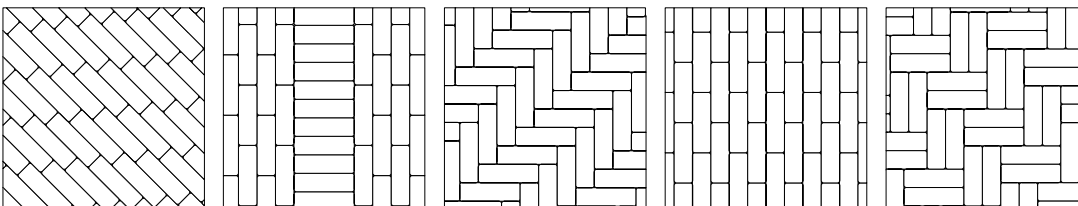

6 x 12 ACCENT PAVERS

Surface and Edges: (Two styles)

- Embossed surface; irregular/chamfered edge, radius corners, small auto-spacer
- OR Smooth surface; straight/chamfered edge detail, small auto spacer
- Chroma Color produced; vibrant facemix layer
- Chroma Shield protected against fading, staining, wear

Colors: Brown, Natural, Onyx, (Buff smooth only)

Ordering / Installation:

- Specify embossed or smooth surface, available by pallet or layer
- Designed for use with Minnetonkas, Barrington, Mezzano, Serano pavers
- Suitable for paths, patios, pool decks, border/insets, vehicular
- Use roller compactor or buffer pad when compacting

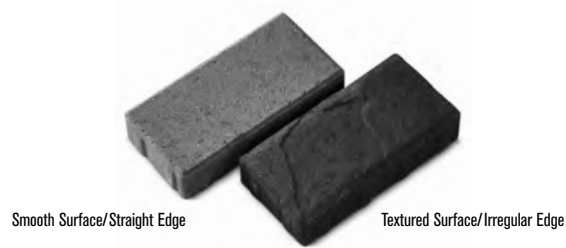

Smooth Surface/Straight Edge

Textured Surface/Irregular Edge



Surface	Dimensions	Face Area	Weight	Units/Layer	Layers	Units/Pallet	Pallet Weight
Smooth	6 x 12 x 2-3/8" H	0.46 sq. ft.	13 lbs.	21	10 (9.7 sq. ft.)	210 (97 sq. ft.)	2,780 lbs.
Embossed	6 x 12 x 2-3/8" H	0.46 sq. ft.	13 lbs.	21	10 (9.7 sq. ft.)	210 (97 sq. ft.)	2,780 lbs.

Dimensions shown are nominal. Pallet square footage is accurate, layers and bands square footages have been rounded to nearest whole number.

SEE PAGES 18/19 for BORDERS & ACCENTING GUIDE

RENO AND TAHOE PAVERS

Surface and Edges:

- Tahoe; textured surface, irregular/chamfered edge detail, small auto-spacer
- Reno; smooth surface, straight/chamfered edge detail, small auto spacer
- Chroma Color produced; vibrant facemix layer

Colors: Beechwood, Cascade, Glacier Creek, Santa Fe

Ordering / Installation:

- Three-piece, one-pallet systems, available by pallet or layer
- Suitable for paths, patios, pool decks, vehicular
- Use 6 x 12 Accent, American Brick, Cobble Stone or Colonial pavers for borders and insets
- Use roller compactor or buffer pad when compacting



TAHOE = Textured Surface/Irregular Edge

RENO = Smooth Surface/Straight Edge



Size	Dimensions	Face Area	Units/Layer	Layers	Units/Pallet	Pallet Weight
Small	5 x 10 x 2-3/8" H	0.33 sq. ft.	8			
Medium	10 x 10 x 2-3/8" H	0.67 sq. ft.	6	8 (11.75 sq. ft)	152 (94 sq. ft.)	2,525 lbs.
Large	15 x 10 x 2-3/8" H	1.01 sq. ft.	5			

Dimensions shown are nominal. Pallet square footage is accurate, layers and bands square footages have been rounded to nearest whole number.

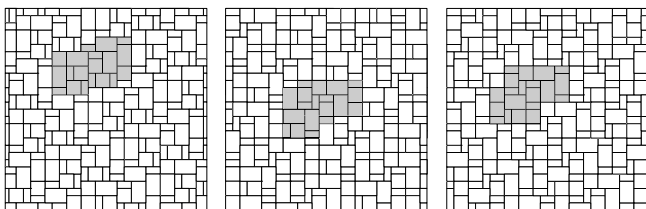

Patterns shown use one complete pallet layer (11.75 sq. ft.).

COLONIAL PAVERS

Surface and Edges:

- Dimpled top, straight/irregular edge detail, small auto-spacer
- Chroma Color produced; vibrant facemix layer



Colors: Beechwood, Moonlight Grey and

*3/4 sq. and Rectangle in Brown, Buff, Onyx; w/ Chroma Shield



Ordering / Installation:

- Palletized separately, available by pallet or band
- Suitable for paths, patios, pool decks, vehicular
- Use 6 x 12 Accent, Colonial 3/4 Square or Rectangle, American Brick or Cobble Stone pavers for borders and insets
- Use roller compactor or buffer pad when compacting

Size	Dimensions	Face Area	Weight	Units/Band	Bands/Pallet	Units/Pallet	Pallet Weight
Half Square	6 x 3 x 2-3/8" H	0.14 sq. ft.	3 lbs.	50 (6.86 sq. ft.)	7	350 (48 sq. ft.)	1,300 lbs.
3/4 Square*	6 x 5 x 2-3/8" H	0.20 sq. ft.	6 lbs.	56 (11.4 sq. ft.)	7	392 (80 sq. ft.)	2,180 lbs.
Square	6 x 6 x 2-3/8" H	0.28 sq. ft.	7 lbs.	50 (14 sq. ft.)	7	350 (98 sq. ft.)	2,690 lbs.
Rectangle*	6 x 10 x 2-3/8" H	0.41 sq. ft.	12 lbs.	45 (18.4 sq. ft.)	5	225 (92 sq. ft.)	2,650 lbs.

Dimensions shown are nominal. Pallet square footage is accurate, layers and bands square footages have been rounded to nearest whole number.

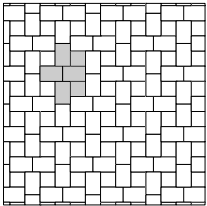

Pattern 1
Square = 25%
Rectangle = 75%

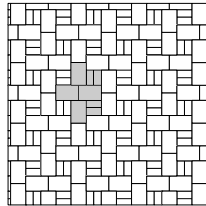

Pattern 2
Square = 25%
Rectangle = 75%

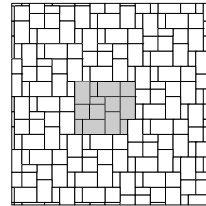

Pattern 3
Half square = 14.81%
Square = 29.63%
Rectangle = 55.56%

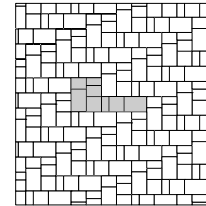

Pattern 4
Half square = 13.37%
3/4 square = 19.75%
Square = 26.75%
Rectangle = 40.13%

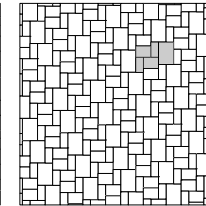

Pattern 5
Half square = 23%
3/4 square = 38%
Rectangle = 38%

LAMONT PAVERS

Surface and Edges:

- Tumbled/aged appearance, straight edge detail, NO auto-spacer
- Thru-mix color; non-facemix



Colors: Antique Brown, Beechwood, Sierra Grey, and

*4 x 8 and 6 x 8; Brown, Buff, Onyx



Ordering / Installation:

- Palletized separately, available by pallet or band
- Suitable for paths, patios, pool decks, vehicular
- Use 6 x 12 Accent, American Brick or Cobble Stone pavers for borders and insets
- Use plate or roller compactor when compacting

Size	Dimensions	Face Area	Weight	Units/Band	Bands/Pallet	Units/Pallet	Pallet Weight
4 x 8*	4 x 8 x 2-3/8" H	0.24 sq. ft.	7 lbs.	80 (19.2 sq. ft.)	5	400 (96 sq. ft.)	2,625 lbs.
6 x 8*	6 x 8 x 2-3/8" H	0.35 sq. ft.	10 lbs.	50 (17.8 sq. ft.)	5	250 (89 sq. ft.)	2,450 lbs.
10 x 8	10 x 8 x 2-3/8" H	0.59 sq. ft.	17 lbs.	40 (23.75 sq. ft.)	4	160 (95 sq. ft.)	2,710 lbs.
12 x 8	12 x 8 x 2-3/8" H	0.71 sq. ft.	21 lbs.	40 (28.5 sq. ft.)	4	160 (114 sq. ft.)	3,170 lbs.

Dimensions shown are nominal. Pallet square footage is accurate, layers and bands square footages have been rounded to nearest whole number.

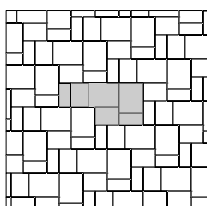

Pattern 1
4 x 8 = 20%
6 x 8 = 30%
10 x 8 = 50%

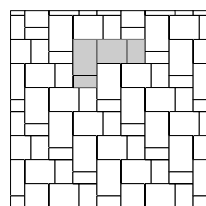

Pattern 2
4 x 8 = 12.5%
6 x 8 = 18%
10 x 8 = 31.2%
12 x 8 = 37.5%

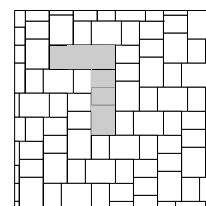

Pattern 3
6 x 8 = 54.5%
10 x 8 = 45.5%

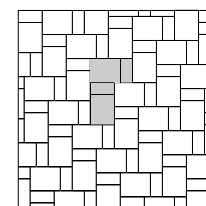

Pattern 4
4 x 8 = 28%
10 x 8 = 72%

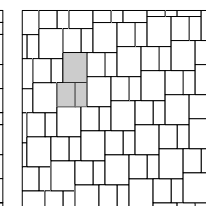

Pattern 5
4 x 8 = 20%
6 x 8 = 30%
10 x 8 = 50%

HOLLAND PAVERS

Surface and Edges:

- Larger than typical Hollands
- Smooth top, beveled edge, small auto-spacer
- Chroma Color produced; vibrant facemix layer



Colors: Antique Copper, Beechwood, Brown, Buff, Moonlight Grey, Rosewood, Natural, Onyx w/Chroma shield



Ordering:

- Available by pallet or band
- Suitable for paths, patios, pool decks, vehicular
- Use 6 x 12 Accent, American Brick or Cobble Stone pavers for borders and insets
- Use plate or roller compactor when compacting

Size	Dimensions	Face Area	Weight	Units/Band	Bands/Pallet	Units/Pallet	Pallet Weight
6cm	9 x 4 x 2-3/8" H	0.24 sq. ft.	7 lbs.	80	5 (19.6 sq. ft.)	400 (98 sq. ft.)	2,785 lbs.
8cm (special order)	9 x 4 x 3-1/8" H	0.24 sq. ft.	9 lbs.	56	5 (13.8 sq. ft.)	280 (69 sq. ft.)	2,560 lbs.

Dimensions shown are nominal. Pallet square footage is accurate, layers and bands square footages have been rounded to nearest whole number.

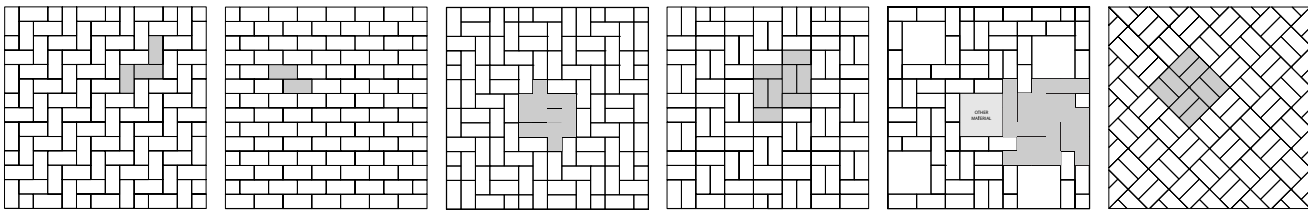

Pattern 1

Pattern 2

Pattern 3

Pattern 4

Pattern 5

Pattern 6

HOLLAND-ECO PERMEABLE PAVER

Surface and Edges:

- Smooth top, beveled edge, large auto-spacer (high flow-rate, eco/permeable)
- Thru-mix color; non-facemix



Colors: Beechwood, Moonlight Grey



Ordering / Installation

- Two-piece, one-pallet system, available by pallet
- Suitable for paths, patios, pool decks, vehicular
- Palletized for machine installation
- Compatible with 8cm Pacific-Eco paver
- Use plate or roller compactor when compacting

Size	Dimensions	Face Area	Weight	Units/Layer	Layers	Units/Pallet	Pallet Weight
Rectangle	5 x 10 x 3-1/8" H	0.33 sq. ft.	13 lbs.	28	8 (10.37 sq. ft.)	280 (83 sq. ft.)	3,050 lbs.
Square	5 x 5 x 3-1/8" H	0.165 sq. ft.	6.5 lbs.	7			

Dimensions shown are nominal. Pallet square footage is accurate, layers and bands square footages have been rounded to nearest whole number.

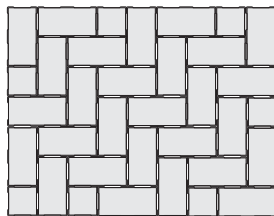

Holland-Eco pallet layer.

Break bond by removing smalls and turning large units.

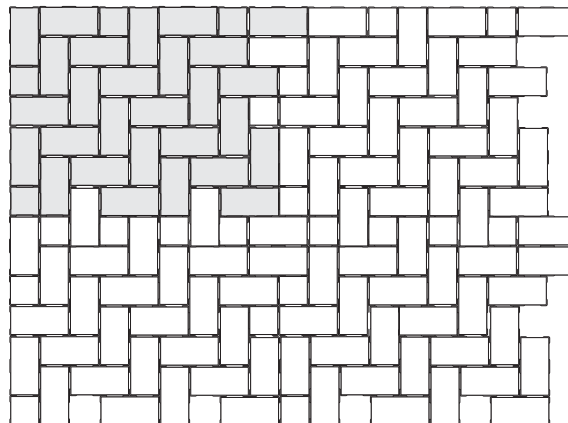

PACIFIC-ECO PERMEABLE PAVER

Surface and Edges:

- Smooth top, beveled edge, large auto-spacer (high flow-rate, eco/permeable)
- Thru-mix color; non-facemix

Colors: Beechwood, Moonlight Grey

Ordering / Installation

- Four-piece, one-pallet system, available by pallet or layer
- Suitable for paths, patios, pool decks, vehicular
- Palletized for machine installation
- Compatible with 8cm Holland-Eco paver
- Use plate or roller compactor when compacting



Size	Dimensions	Face Area	Weight	Units/Layer	Layers	Units/Pallet	Pallet Weight
Sm. Square	5 x 5 x 3-1/8" H	0.17 sq. ft.					
Lg. Square	10 x 10 x 3-1/8" H	0.7 sq. ft.					
Sm. Rectangle	5 x 10 x 3-1/8" H	.35 sq. ft.		28 (13.44 sq. ft.)	7 (425 lbs.)	224 (94 sq. ft.)	2,975 lbs.
Lg. Rectangle	15 x 10 x 3-1/8" H	1.04 sq. ft.					

Dimensions shown are nominal. Pallet square footage is accurate, layers and bands square footages have been rounded to nearest whole number.

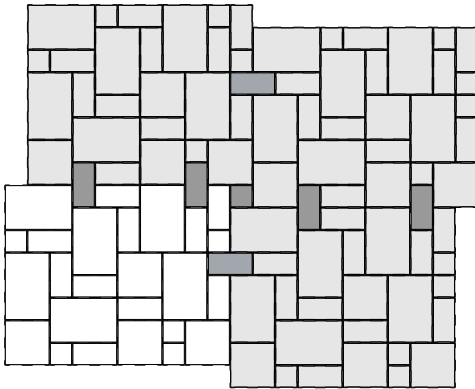

Pacific-Eco pallet pattern for machine install. Knit with Holland-Eco.

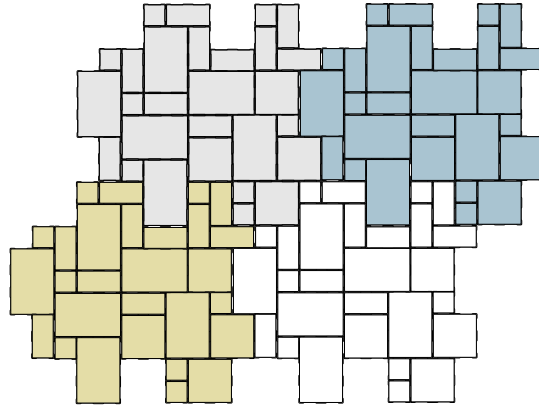

Pacific-Eco pallet layer for conventional install. Pattern uses one full layer.

ACCENTING AND BORDER PAVERS

With the exception of Pacific-Eco and Holland-Eco, all our pavers are 6cm in height – making it easy to mix and match products for accenting and edging to meet your design goals. The endless combinations of all our paver shapes, colors and textures give designers complete freedom to make their hardscape designs truly exceptional.

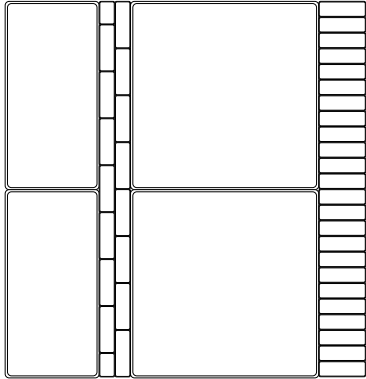

AMERICAN BRICK PAVER:



Basket

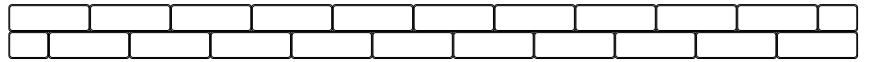

Double Sailor

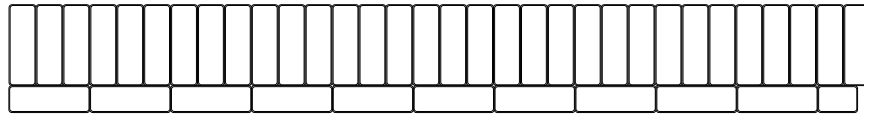

Soldier with Sailor

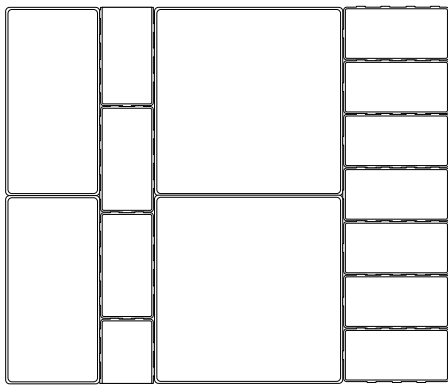

6 X 12 ACCENT PAVERS:

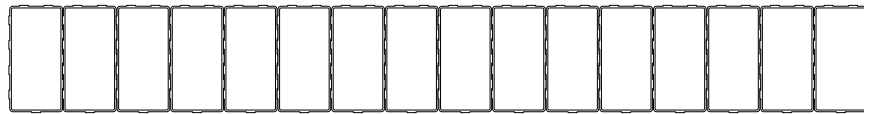

Soldier Course

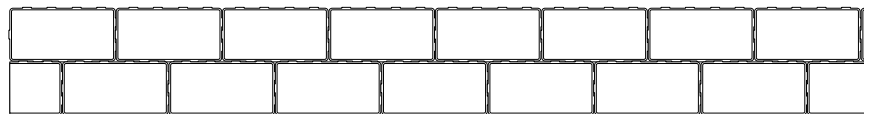

Double Sailor

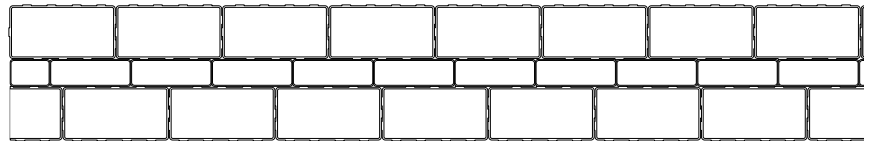

Double Sailor with American Brick

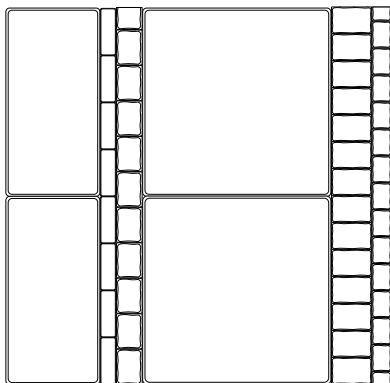

COLONIAL ACCENT:

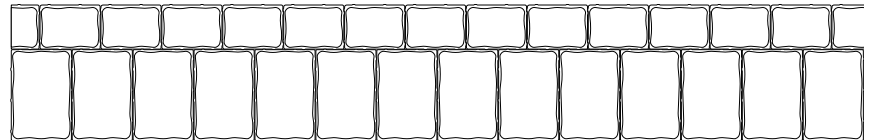

3/4 Square Sailor with 6 x 9 Soldier



6 x 9 Sailor with American Brick Sailor



3/4 Square Sailor with American Brick Sailor

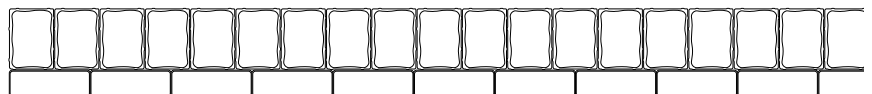

3/4 Square Soldier with American Brick Sailor

Examples shown to scale with a 24" pavers.

LAMONT 4 X 8 AND 6 X 8:

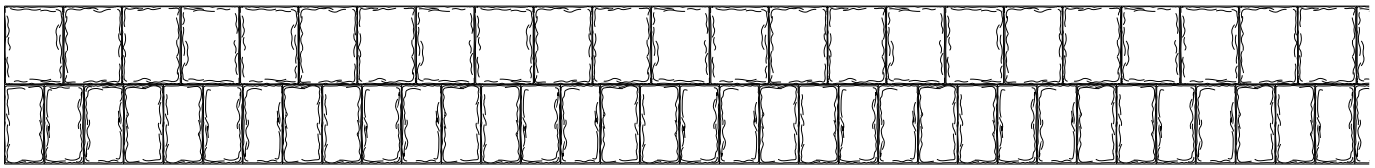

4 x 8 and 6 x 8 Soldier Courses

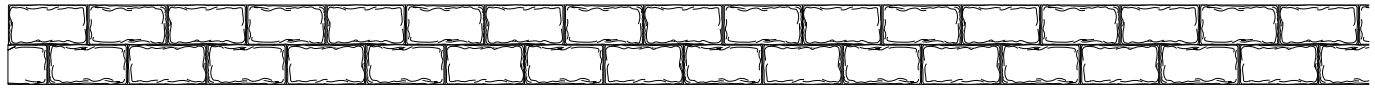

4 x 8 Double Sailor Course

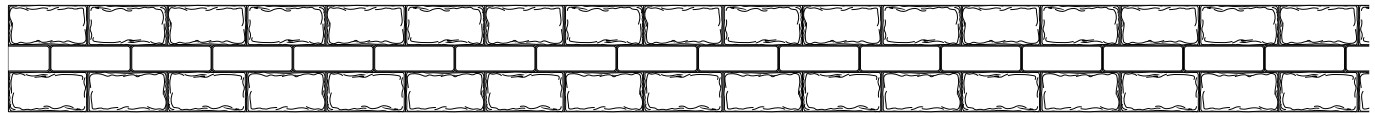

4 x 8 Double Sailor with American Brick

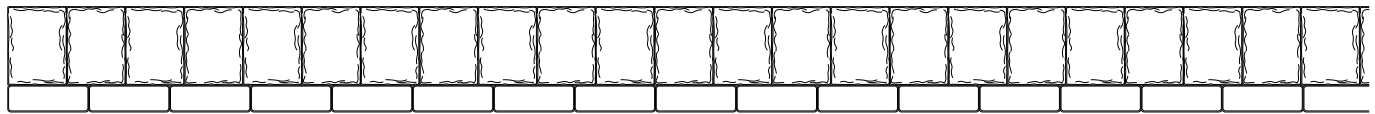

6 x 8 Soldier with American Brick Sailor Course

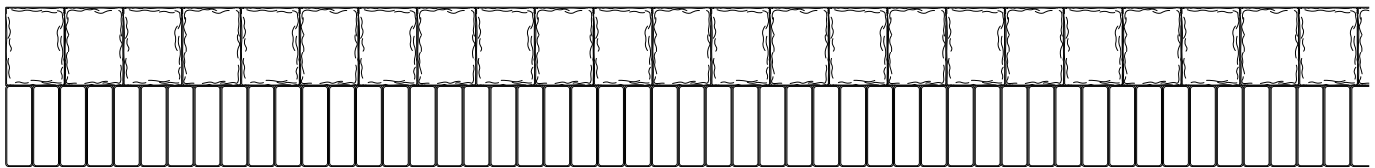

6 x 8 Soldier with American Brick

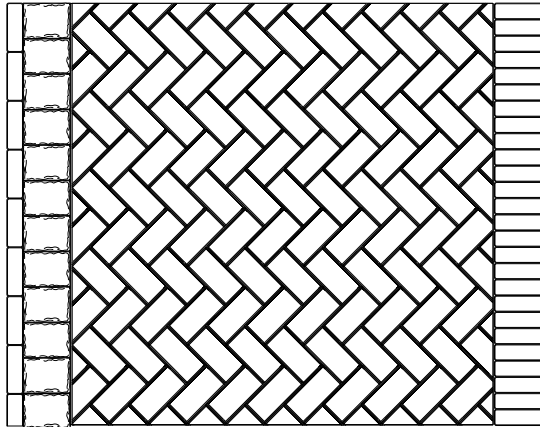

6 x 8 Lamont Soldier + American
Brick Sailor Course

American Brick Soldier
6 x 12 Accent Field

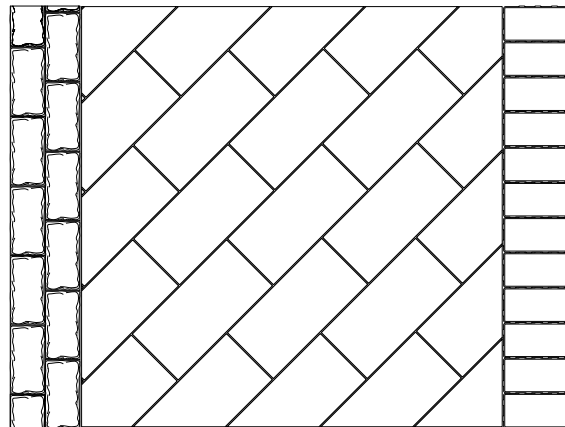

4 x 8 Lamont Double
Sailor Course

6 x 12 Accent Soldier Course
12 x 24 Field

PORCELAIN TILES

Surface and Edges:

- Solid, 2cm porcelain; highly resistant to chemicals, staining, fading and scratching/heavy wear
- Slip resistant, smooth surface, micro-beveled edge, NO spacer-bars



Ordering and Installation:

- Order by color/size, available by carton
- Suitable for paths, patios, elevated decks, rooftops, pool decks, overlays
- Use extreme care to prevent edge damage, use roller compactor or buffer pad when compacting
- Random visuals enhance the natural beauty of this product. To achieve optimal results, all tile should be selected from multiple cartons and shading and graphic arrangement planned prior to installation.
- **Dry Laying on Grass:** The gaps between the slabs should be chosen depending on the overall desired aesthetic.
- **Dry Laying on Gravel:** Gaps of at least 3/16" (5 mm) should be left between slabs, using spacers to set the correct width. Joint may be left empty or filled with fine sand, polymeric sand specifically formulated for porcelain tile or small, clean aggregate, depending on the joint width and desired aesthetic.
- **Dry Laying on Sand:** The gaps between the slabs should be chosen depending on the overall desired aesthetic.
- **Laying on Screed with Adhesive:** Slabs must be laid with open joints of variable width of no less than 3/16" (5 mm).
- **Raised Pavings:** Pedestal contains correct tile spacers for application.

Sizes, Packaging: For available colors, visit: <https://www.daltile.com/xteriors/tread-pavers>

Name	Appearance	Shape	Dimensions	Packaging
Ambassador™	Lineal Quartzite (2 colors)	Rectangle	16 x 48 x 13/16" H	5.16 sq. ft., 1/carton
Assemble™	Agglomerate Stone (3 colors)	Square	32 x 32 x 13/16" H	6.89 sq. ft., 1/carton
Commissary™	Wood (5 colors)	Rectangle & Square**	16 x 48 x 13/16" H	5.16 sq. ft., 1/carton
Delegate™	Compressed Slate (2 colors)	Rectangle	20 x 40 x 13/16" H	5.38 sq. ft., 1/ carton
Dignitary™	French Limestone (3 colors)	Square	24 x 24 x 13/16" H	7.76 sq. ft., 2/carton
Diplomacy™	Belgian Bluestone (2 colors)	Square (special order)	24 x 24 x 13/16" H	7.76 sq. ft., 2/carton
Diplomacy™	Belgian Bluestone (2 colors)	Rectangle	20 x 40 x 13/16" H	5.38 sq. ft., 1/carton

** Deputy Grey and Regent Honey colors also available in 24 x 24 x 13/16" H. Dimensions shown are nominal.

Colors: For available colors, visit: <https://www.daltile.com/xteriors/tread-pavers>



www.daltile.com/xteriors



2cm Porcelain Tile vs. other Outdoor Flooring Products

FEATURE	PORCELAIN PAVERS	CLAY BRICK PAVERS	CAST IN PLACE	CONCRETE PAVERS	NATURAL STONE
Stain Resistance	HIGH	Medium	Low	Low	Low
UV Resistance	WILL NOT FADE	High	Low	Low	High
Scratch Resistance	HIGH	Medium	Low	Low	Low
Freeze Thaw Resistance	FREEZE THAW PROOF	Medium	Low	Low	Low
De-icing Salt Resistance	HIGH	Medium	Low	Low	Low
Acid Resistance	HIGH	Low	Low	Low	Low
Water Absorption (ASTM #373)	< 0.5%	< 8%	< 10%	< 5%	< 5%
Sealing	NEVER	No	Recommended	Recommended	Recommended
Compressive Strength (Psi)	> 30,000	> 8,000?	> 2,500 residential / >4,000 commercial	> 8,000	1,800-19,000*
Weight (lbs/sf)	9	21 - 31	12.5	27 - 36	15-50*

**Varies by stone

Applications

	Target DCOF Wet
Exterior Floor Applications (including pool decking & other wet areas with minimal footwear)	0.60
Ramps & Inclines	0.65

A DCOF (Dynamic Coefficient of Friction) value of 0.42 is the standard for tiles specified for level interior spaces expected to be walked upon when wet, as stated in ANSI A137.1-A326.3. For more information about DCOF and the DCOF AcuTest™, visit daltile.com/DCOF.

APPLICATION NOTES: Suitable for exterior applications in freezing and non-freezing climates, when proper installation methods are followed.

NOTES: Since there are variations in all fired ceramic and natural products, tile and trim supplied for your particular installation may not match samples. Final confirmation should be made from actual tiles and trim prior to installation. Manufactured in accordance with ANSI A137.1 standards. For additional information refer to "Factors to Consider" at: daltile.com/Factors.

Performance

	ASTM#	Paver Result
Water Absorption	C373	< 0.5%
Breaking Strength	C648	> 1000 lbs
Scratch Hardness	MOHS	8.0
Chemical Resistance	C650	Resistant
Abrasion Resistance	C1027	N/A

For addition on test results, visit us at:

daltile.com/information/TestResults

Porcelain is the most resilient outdoor flooring product available.

- UV-resistant
- Scratch and stain resistant
- Chemical and fire-resistant
- Freeze/thaw-resistant
- Slip-resistant



CLASSIC® 6 AND 8 RETAINING WALLS

Ordering and Installation:

- Specify 6 or 8" height, straight or beveled face
- Strong and versatile, efficient to build, one-unit system
- Matching half and corner block (2-3 day lead time req'd.)
- 1.0" setback; adjustable
- Cap with 3" or 4" Universal or Chiseled Cap
- Available by layer or pallet

Classic 6 Colors: (straight or beveled face):

- Bluestone
- Sandstone Brown
- Santa Fe

Classic 6 Colors: (straight face)

- Charcoal
- Grey
- Sandstone

Classic 8 Colors: (straight or beveled face)

- Grey
- Sandstone

Classic 8 Colors: (straight face)

- Charcoal
- Sandstone Brown

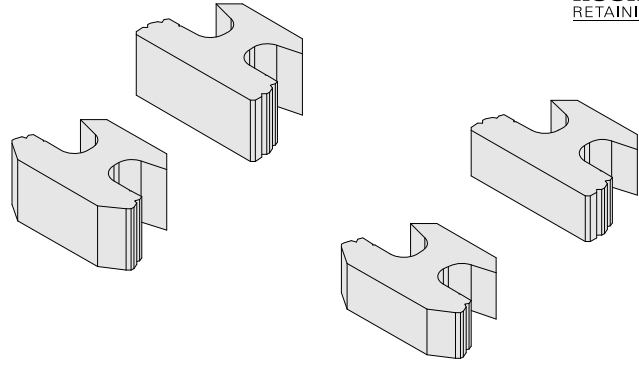

ROCKWOOD
RETAINING WALLS
A better way.™

Classic 6 Blocks	Dimensions	Face Area	Weight	Units/Layer	Layers	Units/Pallet	Pallet Weight
Straight Face	18 x 12 x 6" H	0.75 sq. ft.	64 lbs.	12	3	36 (27 sq. ft.)	2,354 lbs.
Straight Base (grey only)	18 x 12 x 6" H	0.75 sq. ft.	64 lbs.	12	3	36 (27 sq. ft.)	2,354 lbs.
Beveled Face	18 x 12 x 6" H	0.75 sq. ft.	60 lbs.	12	3	36 (27 sq. ft.)	2,210 lbs.
Half-Block	9 x 12 x 6" H	0.38 sq. ft.	30 lbs.	12	1	12 (4.56 sq. ft.)	410 lbs.
Corner Block	13 x 5.5 x 6" H	0.54 sq. ft.	32 lbs.	12	1	12 (6.48 sq. ft.)	434 lbs.

To estimate number of units, divide total sq. ft. by 0.75 for Classic 6.

Classic 8 Blocks	Dimensions	Face Area	Weight	Units/Layer	Layers	Units/Pallet	Pallet Weight
Straight Face	18 x 12 x 8" H	1.0 sq. ft.	85 lbs.	12	3	36 (36 sq. ft.)	3,110 lbs.
Straight Base (grey only)	18 x 12 x 8" H	1.0 sq. ft.	85 lbs.	12	3	36 (36 sq. ft.)	3,110 lbs.
Beveled Face	18 x 12 x 8" H	1.0 sq. ft.	79 lbs.	12	3	36 (36 sq. ft.)	2,895 lbs.
Half-Block	9 x 12 x 8" H	0.5 sq. ft.	39 lbs.	12	1	12 (6 sq. ft.)	518 lbs.
Solid Corner Block**	18 x 9 x 8" H	1.0 sq. ft.	100 lbs.	5	4	20 (20 sq. ft.)	2,050 lbs.

Corners are split on one long and one short side. ** Rochester and Beaver Dam only. Dimensions shown are nominal.

CLASSIC® 8 DOT RETAINING WALL AND CAPS

Ordering and Installation:

- Straight face, 1" setback; adjustable
- Beveled face* is SPECIAL ORDER and can be made in any color. Minimum quantity required, customer must take entire production run. Returns not allowed.
- Iowa, Minnesota and Wisconsin DOT approved
- Manufactured in Thorp, WI
- Available by pallet

Colors: Sandstone, Grey

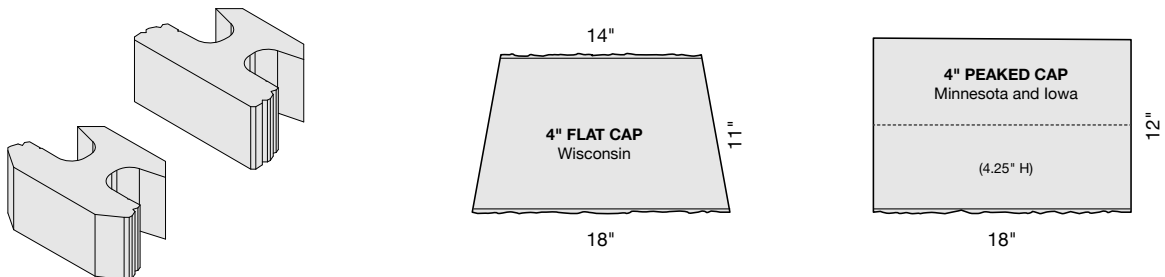

ROCKWOOD
RETAINING WALLS
A better way.™

DOT Blocks/Caps	Dimensions	Face Area	Weight	Units/Layer	Layers	Units/Pallet	Pallet Weight
Straight Face	18 x 12 x 8" H	1.0 sq. ft.	87 lbs.	12	3	36 (36 sq. ft.)	3,182 lbs.
Beveled Face*	18 x 12 x 8" H	1.0 sq. ft.	82 lbs.	12	3	36 (36 sq. ft.)	3,002 lbs.
4" Flat Cap (WI)	18/14 x 11 x 4" H	1.33 in. ft.	55 lbs.	9	5	45 (60 in. ft.)	2,520 lbs.
4" Peaked Cap (MN and IA)	18 W x 12 x 4" H	1.5 in. ft.	70 lbs.	8	4	32 (48 in. ft.)	2,290 lbs.

Dimensions shown are nominal.

CLASSIC COLONIAL® 6 RETAINING WALL

Ordering and Installation:

- Multi-unit appearance, rustic face
- A strong and versatile, efficient to build, one-unit system
- Matching base, corner and half blocks (2-3 day lead time req'd.)
- Cap with 4" Universal or Chiseled Cap
- 1.0" setback; adjustable
- To estimate number of Classic Colonial 6 units, divide total sq. ft. by 0.75
- Colonial 18 and 6/12 18 units are palletized separately
- Available by layer or pallet

ROCKWOOD
RETAINING WALLS
A better way™

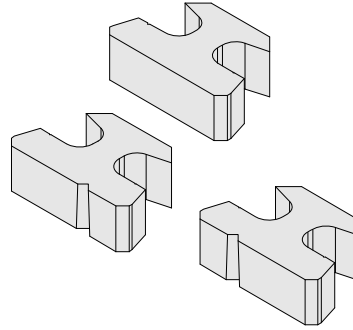

Colors: Bluestone, Santa Fe, Sandstone Brown

Blocks	Dimensions	Face Area	Weight	Units/Layer	Layers	Units/Pallet	Pallet Weight
Colonial 18	18 x 12 x 6" H	0.75 sq. ft.	60 lbs.	12	3	36 (27 sq. ft.)	2,260 lbs.
Colonial 6/12	18 x 12 x 6" H	0.75 sq. ft.	60 lbs.	12	3	36 (27 sq. ft.)	2,260 lbs.
Base Block	18 x 12 x 6" H	0.75 sq. ft.	60 lbs.	12	3	36 (27 sq. ft.)	2,260 lbs.
Half-Block	9 x 12 x 6" H	0.38 sq. ft.	30 lbs.	12	1	12 (4.56 sq. ft.)	410 lbs.
Corner Block	13 x 5.5 x 6" H	0.54 sq. ft.	32 lbs.	12	1	12 (6.48 sq. ft.)	434 lbs.

Dimensions shown are nominal.

OLYMPIC RETAINING WALL

Ordering and Installation:

- Single-unit, smooth surface w/ dramatic beveled edges
- Partial cores with channel/anchor bar design, matching corner/pillar block
- Builds vertical, freestanding garden/retaining walls, planters, seatwalls and outdoor living features
- Cap with Contemporary Wall cap
- Available by pallet

ROCKWOOD
RETAINING WALLS
A better way™

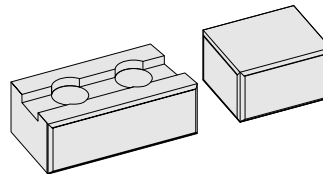

Colors: Beechwood, Cascade, Onyx

Blocks	Size	Area	Unit Weight	Units/Pallet	Pallet Weight
Wall	17 x 10 x 6" H	0.72 sq. ft.	67 lbs.	48 (34.5 sq. ft.)	3,266 lbs.
Seatwall/Corner/Pillar	12 x 10 x 6" H	0.50 sq. ft.	57 lbs.	48 (24 sq. ft.)	2,785

Dimensions shown are nominal.



IMPORTANT: Olympic corner/pillar blocks have one non-beveled bottom edge. Install blocks so this side is NOT exposed in freestanding wall, pillar and corner construction.

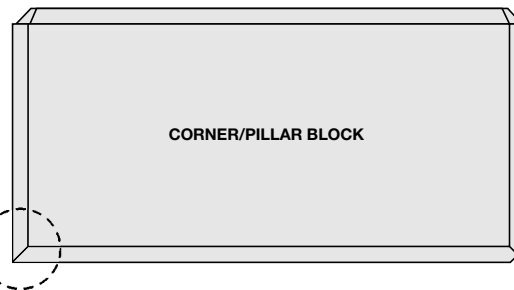
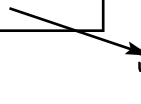

PREMIER 6 RETAINING WALL

Ordering and Installation:

- Easy-to-handle for increased efficiencies in the field
- Straight-thru core design; cores fill quickly & easily
- Straight-split face, 0.50" (4.7") setback
- Ability to construct tight radius turns
- Cap with 3" or 4" Universal or Chiseled Cap
- Available by pallet

Colors: Bluestone, Santa Fe, Onyx

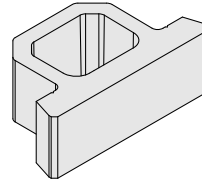

ROCKWOOD
RETAINING WALLS
A better way.

Blocks	Dimensions	Area	Unit Weight	Units/Pallet	Pallet Weight
Wall	18 x 12 x 6" H	0.74 sq. ft.	43.5 lbs.	45 (33.3 sq. ft.)	2,010 lbs.
Corner (solid)	16 x 8 x 6" H	0.66 sq. ft.	74.5 lbs.	20 (13.2 sq. ft.)	1,540 lbs.

Dimensions shown are nominal.

PREMIER 8 RETAINING WALL



Ordering and Installation:

- Easy-to-handle for increased efficiencies in the field
- Straight-thru core design; cores fill quickly & easily
- Straight-split face, 1.0" (7") setback
- Ability to construct tight radius turns
- Cap with 4" Universal or Chiseled Cap
- Available by pallet

Colors: Sandstone, Sandstone Brown, Charcoal, Grey

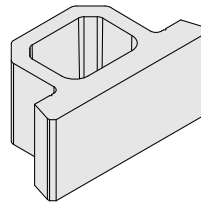

ROCKWOOD
RETAINING WALLS
A better way.

Blocks	Dimensions	Face Area	Weight	Units/Layer	Layers	Units/Pallet	Pallet Weight
Premier 8	18 x 12 x 8" H	1 sq. ft.	57 lbs.	9	5	45 (45 sq. ft.)**	2,615 lbs.
Solid Corner*	18 x 9 x 8" H	1 sq. ft.	100 lbs.	5	4	20 (20 sq. ft.)	2,050 lbs.

Corners are split on one long and one short side. *Rochester and Beaver Dam only. Dimensions shown are nominal. ** 36 units/pallet from Rochester, 2,102 lb. pallet.

This revolutionary block design makes Premier the most efficient SRW blocks ever. Weighing nearly half that of comparable SRW's, they beat all other block systems for freight efficiencies and ease of construction.

- Easy to handle for increased efficiencies in the field
- No cumbersome/expensive pins or clips
- Capable of tight radius turns
- Significant freight advantages, more sq. ft. per truckload
- Manufactured in accordance with ASTM C1372.

Straight-thru cores fill easily to create vertical stone columns, giving Premier incredible connection strength and resistance to shear.

Premier's bottom side anchor bar creates an automatic setback.

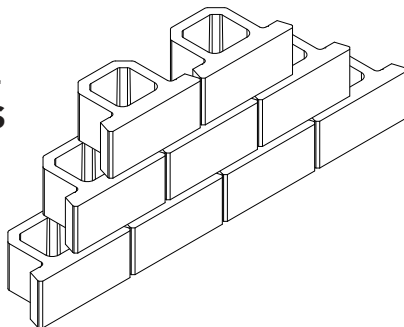
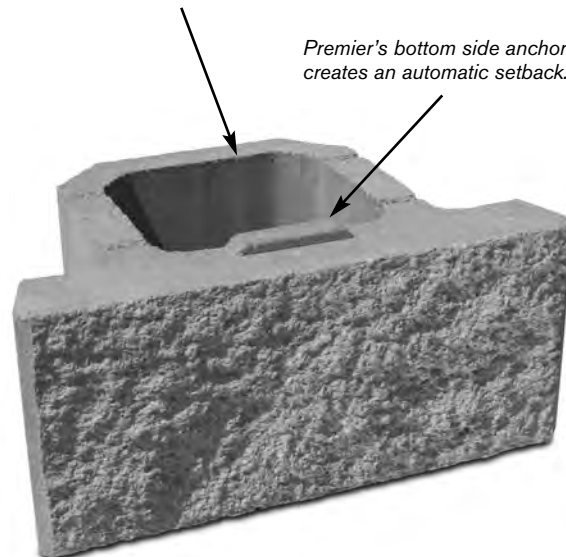

VINTAGE 6 RETAINING WALLS

Ordering and Installation:

- Three-piece system, all sizes on one pallet
- Spilt-faced, tumbled vertical wall system with anchor bar connection
- Builds straight or 8' radius without cutting
- Builds freestanding or retaining walls
- End blocks are split three sides, corner/pillar block split two sides
- Order Split face or tumbled
- Available by set or pallet

Colors: Beechwood, Bluestone, Cascade, Santa Fe

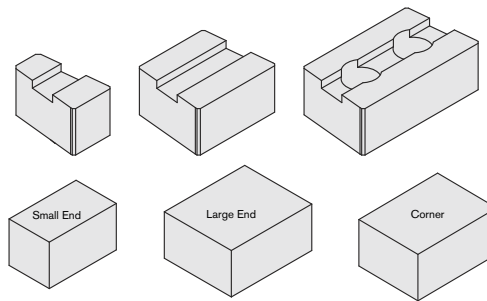

ROCKWOOD
RETAINING WALLS
A better way.



Blocks	Dimensions	Face Area	Weight	Pallets	Pallet Weight
Small (S)	6 x 10 x 6" H	0.25 sq. ft.			
Medium (M) (sold in sets)	12 x 10 x 6" H	0.50 sq. ft.	137.5 lbs.	20 sets (30 sq. ft.)	2,790 lbs.
Large (L)	18 x 10 x 6" H	0.75 sq. ft.			
Small End block (SE) (sold in sets)	6 x 10 x 6" H	0.42 sq. ft.	81.50 lbs.	8 sets (10 sq. ft.)	702 lbs.
Large End block (LE)	12 x 10 x 6" H	0.83 sq. ft.			
Corner/Pillar Block (full pallets only)	12 x 9 x 6" H	0.50 sq. ft.	48 lbs.	30 (15 sq. ft.)	1,490 lbs.

Dimensions shown are nominal.

LAKELAND RETAINING WALLS

Ordering and Installation:

- Tumbled, three-piece, two-pallet system
- Builds vertical, freestanding garden/retaining walls, planters, seatwalls and outdoor living features
- Builds right angles and straight walls
- Cap with 3" or Chiseled Cap
- To estimate number of units, divide total sq. ft. by 0.33
- Available by pallet

Colors: Beechwood, Bluestone, Cascade, Santa Fe, Onyx (Standard available non-tumbled in Onyx)

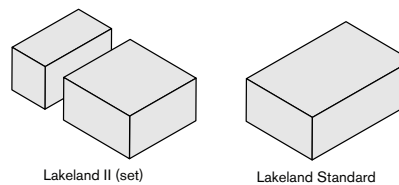

ROCKWOOD
RETAINING WALLS
A better way.



Blocks	Dimensions	Face Area	Weight	Layers	Units/Pallet	Pallet Weight
Lakeland Small (2 piece sets)	4 x 8 x 4" H	0.33 sq. ft.	31 lbs.	4 (20 sets)	80 sets (26 sq. ft.)	2,530 lbs.
Lakeland Medium	8 x 8 x 4" H	0.33 sq. ft.	31 lbs.	4 (20 units)	80 (26 sq. ft.)	2,530 lbs.

Dimensions shown are nominal.

RIVERLAND RETAINING WALL

Ordering and Installation:

- Tumbled, three-piece, one-pallet system
- Builds 7 foot 8 inch radius without cutting
- Cap with 3" or Chiseled Cap
- Available by pallet

Colors: Beechwood, Bluestone, Cascade, Santa Fe, Onyx

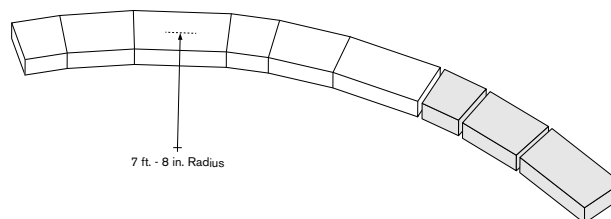

ROCKWOOD
RETAINING WALLS
A better way.



Blocks	Size	Face Area	Weight	Layers	Units/Pallet	Pallet Weight
Riverland Small	8 x 8 x 4" H					
Riverland Medium (3 piece sets)	12 x 8 x 4" H	1.0 sq. ft.	90 lbs.	6 (5 sets)	30 (30 sq. ft.)	2,750 lbs.
Riverland Large	16 x 8 x 4" H					

Dimensions shown are nominal.

COTTAGE STONE RETAINING WALL

Ordering and Installation:

- Trapezoid design, split face front/back, beveled face,
- Curved bottom aids fast install, ideal for small garden walls, tree rings and planters
- Rear-lip creates 0.5" setback
- Cap with Mini-Cap
- Available by pallet, pallets cannot be double stacked

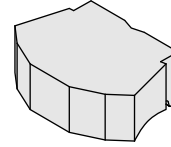

ROCKWOOD
RETAINING WALLS
A better way.

Colors: Charcoal, Grey, Sandstone, Sandstone Brown

Block	Dimensions	Face Area	Weight	Units/Layer	Layers	Units/Pallet	Pallet Weight
Cottage Stone	12 x 8.5 x 4" H	0.33 sq. ft.	25 lbs.	16	6	96 (31.68 sq. ft.)	2,450 lbs.

To estimate number of units, divide total sq. ft. by 0.33

Mini-Cap	8/6 x 9.25 x 3" H (Front)	0.67 in. ft.	15.2 lbs.	52	2	104 (60 in. ft.)	1,630 lbs.
----------	---------------------------	--------------	-----------	----	---	------------------	------------

Dimensions shown are nominal. To estimate Mini-Cap, divide wall length by 0.58

CONTEMPORARY RETAINING WALL

Ordering and Installation:

- Three-piece set, one-pallet system
- Smooth surfaces, beveled edges, matching Corner/Pillar and Cap blocks
- Builds vertical, freestanding garden/retaining walls, planters, seatwalls and outdoor living features
- Available by pallet

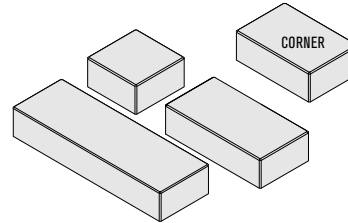

ROCKWOOD
RETAINING WALLS
A better way.

Colors: Beechwood, Cascade, Onyx

Block	Dimensions	Face Area	Weight	Layers	Units/Pallet	Pallet Weight
Small	8 x 8 x 4" H					
Medium	16 x 8 x 4" H	1.33 sq. ft./set	122 lbs./set	5 (4 sets ea.)	20 sets (26.6 sq. ft.)	2,480 lbs.
Large	24 x 8 x 4" H					
Corner/Pillar Block	12 x 8 x 4" H	0.33 sq. ft.	35 lbs.	4 (20 units)	80 (26.6 sq. ft.)	2,850 lbs.
Contemporary Wall Cap	24 W x 12 x 2-3/8" H	2 in. ft.	50 lbs.	6 (8 units)	48 (96 in. ft.)	2,450 lbs.

Dimensions shown are nominal.

BARN PLANK GARDEN WALL

Surface and Edges:

- Deep splits, radius edges with detailed grain top, sides and ends
- Strong and durable 10,000 psi wet cast concrete

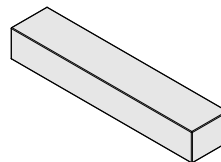

 *Silver Creek*
STONWORKS

Colors: Mahogany or Weathered Grey

Ordering / Installation:

- Lifting device recommended
- Available by pallet

Item	Dimensions	Area (ea.)	Weight	Units/pallet	Pallet Weight
Garden Wall	40 x 8 x 6" H	1.66 sq. ft.	156 lbs.	16 (26.56 sq. ft.)	2,546 lbs.

Dimensions shown are nominal.

SPECIAL ORDER PRODUCTS can be made in any color. Set-up fee and minimum quantity required, customer must take entire production run. Returns not allowed.

STONEHEDGE 6 RETAINING WALL (special order)

Ordering and Installation:

- Split-face front and back
- Vertical system, anchor bar integrates with Classic block systems
- Creates seatwalls, enclosures and privacy walls
- To estimate number of units, divide total sq. ft. by 0.75

Color: Special Order

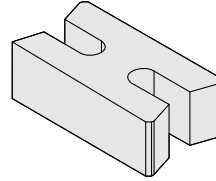

ROCKWOOD
RETAINING WALLS
A better way.

Blocks	Dimensions	Face Area	Weight	Units/Layer	Layers	Units/Pallet	Pallet Weight
Straight	18 x 10 x 6" H	0.75 sq. ft.	64 lbs.	8	3	24 (18 sq. ft.)	1,586 lbs.

Dimensions shown are nominal.

CLASSIC COLONIAL® 8 RETAINING WALL (special order)

Ordering and Installation:

- Multi-unit appearance, rustic face
- A strong and versatile, efficient to build, one-unit system
- Matching base, corner and half blocks (2-3 day lead time req'd.)
- Cap with 4" Universal or Chiseled Cap
- 1.0" setback; adjustable
- Order Colonial 18 and 6/12 18 units separately

Color: Special Order

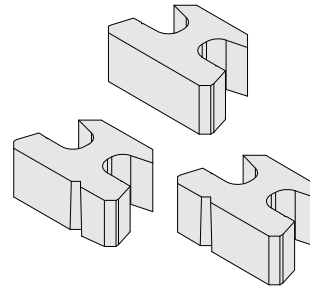

ROCKWOOD
RETAINING WALLS
A better way.

Blocks	Dimensions	Face Area	Weight	Units/Layer	Layers	Units/Pallet	Pallet Weight
Colonial 18	18 x 12 x 8" H	1.0 sq. ft.	85 lbs.	12	3	36 (36 sq. ft.)	3,110 lbs.
Colonial 6/12	18 x 12 x 8" H	1.0 sq. ft.	85 lbs.	12	3	36 (36 sq. ft.)	3,110 lbs.
Base Block (grey only)	18 x 12 x 8" H	1.0 sq. ft.	85 lbs.	12	3	36 (36 sq. ft.)	3,110 lbs.
Half-Block	9 x 12 x 8" H	0.50 sq. ft.	39 lbs.	12	1	12 (6 sq. ft.)	518 lbs.
Corner Block	13 x 5.5 x 8" H	0.72 sq. ft.	40 lbs.	12	1	12 (8.64 sq. ft.)	530 lbs.

Dimensions shown are nominal.

RECON RETAINING WALL



Ordering and Installation:

- Strong, wet cast blocks; 1,457 to 4,088 lbs. ea.
- 24" to 84" D x 48" W x 16" H
- Regular corner and cap blocks
- Half block (24" or 39" deep)
- Full fence or full high end/cap blocks
- Passed current Wisconsin and Minnesota DOT requirements
- Order by size/face style, by each

Color: Natural/grey; stain after installation

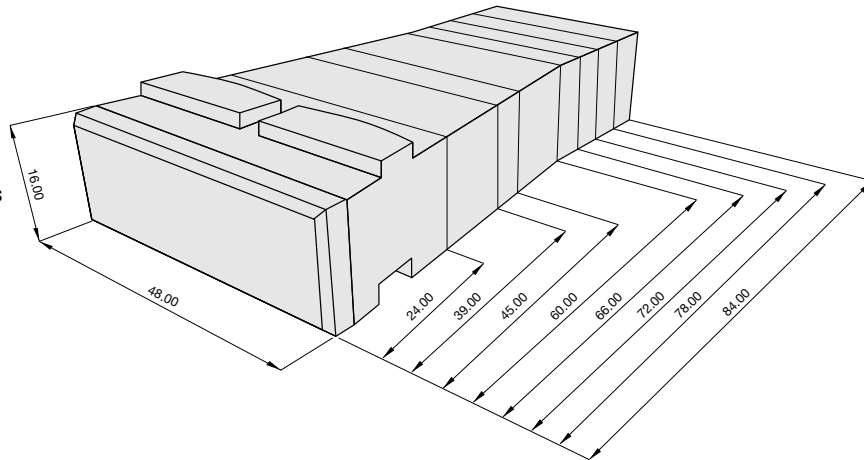

Block	Size W x D x H	Face Area	Unit Weight
Full Base Block - 24"	48 x 24 x 16" H	5.33 sq. ft.	1,457 lbs.
Full Base Block - 39"	48 x 39 x 16" H	5.33 sq. ft.	2,201 lbs.
Full Base Block - 45"	48 x 45 x 16" H	5.33 sq. ft.	2,491 lbs.
Full Base Block - 60"	48 x 60 x 16" H	5.33 sq. ft.	3,115 lbs.
Full Base Block - 66"	48 x 66 x 16" H	5.33 sq. ft.	3,416 lbs.
Full Base Block - 72"	48 x 72 x 16" H	5.33 sq. ft.	3,660 lbs.
Full Base Block - 78"	48 x 78 x 16" H	5.33 sq. ft.	3,902 lbs.
Full Base Block - 84"	48 x 84 x 16" H	5.33 sq. ft.	4,088 lbs.
Full Top Block - 24"	48 x 24 x 16" H	5.33 sq. ft.	971 lbs.
Regular Corner	48 x 24 x 16" H	5.33 sq. ft.	1,401 lbs.
Corner Top	48 x 24 x 16" H	5.33 sq. ft.	1,103 lbs.
Half Block 24"	48 x 24 x 16" H	5.33 sq. ft.	667 lbs.
Half Block 39"	48 x 36 x 16" H	5.33 sq. ft.	973 lbs.
Capstone	48 x 26 x 6.5" H	2.16 sq. ft.	551 lbs.
Fence Middle Block	16 x 48 x 24" H	2.66 sq. ft.	1,449 lbs.
Fence Middle End Block	16 x 48 x 24" H	2.66 sq. ft.	1,476 lbs.
Half Fence Middle End Block	16 x 24 x 24" H	2.66 sq. ft.	709 lbs.
Guardrail Middle Block	16 x 48 x 24" H	2.66 sq. ft.	1,373 lbs.

Dimensions shown are nominal.



OUTCROPPING RETAINING WALL

Ordering and Installation:

- Strong, wet cast wall blocks for serious performance and curb appeal
- 6", 12", 18" and 24" heights
- Fourteen unique shapes in 2' to 6' widths
- 15" setback (3")
- Lifting device required, available for purchase or rent (53 lbs.)
- Use Rosetta Technical Guide for patterns/installation
- Available by pallet

Colors: Copper Canyon, Fond du Lac, Pacific Grey



Pallets	Dimensions	Area/Pallet	Pallet Weight
Pallet A	3.5' x 1' H - 4' x 1' H - 5' x 1' H - 5.5' x 1' H	18 sq. ft.	4,000 lbs.
Pallet B	2' x .5' H - 3' x .5' H - 3' x 1' H - 4' x .5' H - 4.5' x 1' H - 6' x 1' H	18 sq. ft.	4,000 lbs.
Pallet C	2' x .5' H - 3' x .5' H - 5' x 1.5' H - 4' x 2' H	18 sq. ft.	4,000 lbs.
Corner Pallet (3/pallet)	30" x 4' x 1' H	19.5 sq. ft.	3,650 lbs.

Dimensions shown are nominal.

KODAH RETAINING WALL

Ordering and Installation:

- Four-unit system on one pallet
- Two-sided, wet cast blocks build freestanding, vertical seat and retaining walls
- Matching corner/end blocks
- Use Rosetta Technical Guide for patterns/installation
- Available by pallet

Colors: Copper Canyon, Fond du Lac, Pacific Grey



Dimensions	Weight Each	Units/Pallet	Pallet Weight
42 x 10.5 x 6" H	200 lbs.	6 (10.5 sq. ft.)	(21 sq. ft.) 2,400 lbs
30 x 10.5 x 6" H	140 lbs.	3 (3.75 sq. ft.)	
21 x 10.5 x 6" H	100 lbs.	6 (5.28 sq. ft.)	
12 x 10.5 x 6" H	50 lbs.	3 (1.5 sq. ft.)	
Corner Pallet (21 x 10.5 x 6" H)	100 lbs.	16 (21 sq. ft.)	2,400 lbs.

Dimensions shown are nominal.



Rosetta installation and pattern guides: <http://tinyurl.com/33wavfz4>



RETAINING WALL CAPS

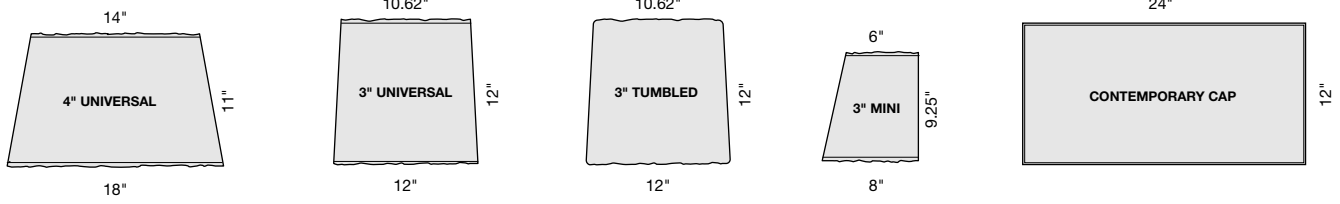

4" Universal Cap

- Split face front/back
- Available by layer

Colors: Bluestone, Charcoal, Grey, Sandstone, Sandstone Brown, Santa Fe

3" Universal Cap

- Split face front/back
- Available by layer

Colors: Beechwood, Bluestone, Cascade, Grey, Santa Fe, Onyx

3" Tumbled Cap

- Smooth, tumble/aged appearance
- Available by layer

Colors: Beechwood, Bluestone, Cascade, Santa Fe

Mini-Cap (Cottage Stone)

- Split face front/back
- Available by layer

Colors: Brown, Charcoal, Grey, Sandstone, Sandstone Brown

Contemporary Cap

- Smooth top/sides, beveled edges
- Available by pallet layer

Colors: Buff, Cascade, Onyx

Cap	Dimensions	Face	Weight	Units/Layer	Layers	Units/Pallet	Pallet Weight
4" Universal*	18 W x 11 x 4" H (Front)						
(Split face front/back)	14 W x 11 x 4" H (Back)	1.33 Ln. ft.	54 lbs.	9	5	45 (60 ln. ft.)	2,480 lbs
3" Universal & 3" Tumbled	12 x 12 x 3" H (Front)						
(Split face front/back)	10.62 x 12 x 3" H (Back)	11.25"	26 lbs.	12	4	48 (45 ln. ft.)	1,298 lbs.
Mini-Cap**	8 x 9.25 x 3" H (Front)						
	6 x 9.25 x 3" H (Back)	0.67 Ln. ft.	15.2 lbs.	522	104 (60 ln. ft.)	1,630 lbs.	
Contemporary Cap	24 W x 12 x 2-3/8" H	2 Ln. ft.	50 lbs.	6	8	48 (96 ln. ft.)	2,450 lbs

Dimensions shown are nominal.

*To estimate Universal Cap, divide wall length by 1.33

**To estimate Mini Cap, divide wall length by 0.58.

DOT APPROVED RETAINING WALL CAPS

Ordering and Installation:

- Order by type
- Iowa, Minnesota and Wisconsin DOT approved
- Manufactured in Thorp, WI

Ordering and Installation:

- Available by pallet or layer

Colors: Sandstone, Grey

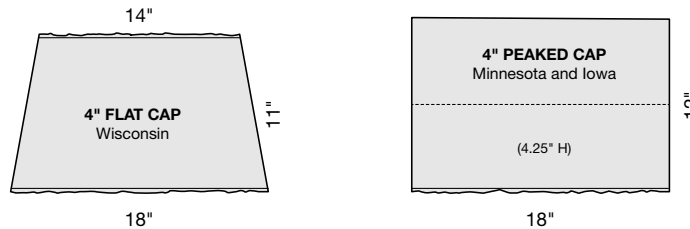

DOT Caps	Dimensions	Face Area	Weight	Units/Layer	Layers	Units/Pallet	Pallet Weight
4" Flat Cap (WI)	18/14 x 11 x 4" H	1.33 ln. ft.	55 lbs.	9	5	45 (60 ln. ft.)	2,520 lbs.
4" Peaked Cap (MN and IA)	18 W x 12 x 4" H	1.5 ln. ft.	70 lbs.	8	4	32 (48 ln. ft.)	2,290 lbs.

Dimensions shown are nominal.

ROCKWOOD
RETAINING WALLS
A better way.

BARN PLANK STEP

Ordering and Installation:

- Strong, wet cast concrete, deep splits/detailed grain on 5-sides
- Lifting device recommended
- Available by piece



Colors: Mahogany, Weathered Grey

Style	Dimensions	Weight	Units/Pallet	Pallet Weight
Barn Plank Step	48 x 18 x 5.75" H	450 lbs.	4	1,850 lbs.

Dimensions shown are nominal.

CHISELED STEPS

Ordering and Installation:

- Strong, wet cast concrete, order by style two styles;
 - ONE-SIDED; Chiseled riser, smooth tread
 - THREE-SIDED; Chiseled riser and sides, rough tread
- One and three-sided steps CANNOT be used together
- Lifting device recommended
- Available by piece



Colors: Bluestone, Buff, Indiana Limestone

Style	Dimensions	Weight	Units/Pallet	Pallet Weight
One-sided	48 x 18 x 5.75" H	435 lbs.	4	1,790 lbs.
Three-sided	48 x 18 x 5.75" H	435 lbs.	4	1,790 lbs.

Dimensions shown are nominal.

GRAND STEP

Ordering and Installation:

- Two looks with one unit; deep bevel front, smooth tread/sides
 - Smooth riser on one side
 - Straight-split on the other
- Lifting device recommended
- Available by pallet

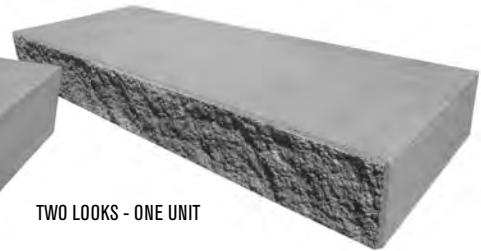

TWO LOOKS - ONE UNIT

Colors: Beechwood, Buff, Charcoal, Natural

Dimensions	Area	Weight	Units/Pallet	Pallet Weight
48 x 18 x 6" H	6.0 sq. ft.	409 lbs.	6 (32 sq. ft.)	2,504 lbs.

Dimensions shown are nominal.

STEPPING STONES

Ordering and Installation:

- Strong, wet cast reproductions of handcrafted limestone originals
- Four unique shapes, chiseled edge; 1.75" H, (ave. 3.75 sq. ft. ea.)
- Available by pallet, pallets CANNOT be double stacked

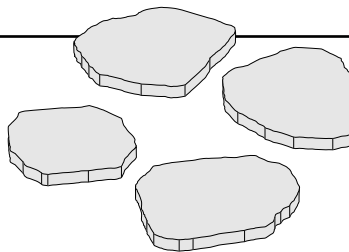

Colors: Bluestone, Indiana Limestone, Buff

Dimensions	Weight/Set	Sets/Pallet	Pallet Weight
1.75" H, (4 unique shapes)	213 lbs.	5 (75 sq. ft.)	1,115 lbs.

CHISELED CAPS AND TOPS

- Strong, wet cast reproductions of handcrafted limestone originals
- Available by pallet or piece, pallets CANNOT be double stacked



Colors: Bluestone, Buff, Indiana Limestone

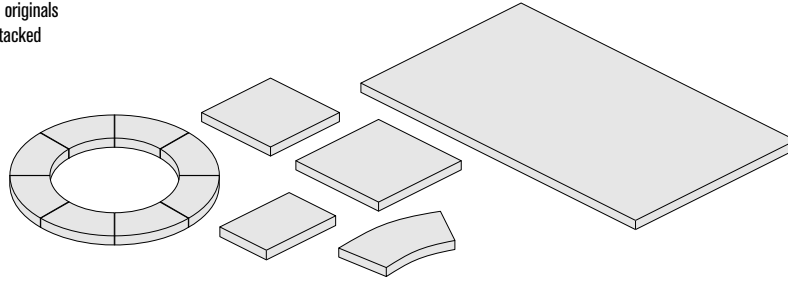

Item	Dimensions	Face Area	Weight	Units/Pallet	Pallet Weight
25" Pillar Cap	25 x 25 x 2.25" H	4.34 sq. ft.	110 lbs.	6 (26.04 sq. ft.)	710 lbs.
30" Pillar Cap	30 x 30 x 2.25" H	6.25 sq. ft.	125 lbs.	6 (37.50 sq. ft.)	800 lbs.
12" Radius Seatwall Cap	18.75 x 12 x 2.25" H	1.56 sq. ft.	39 lbs.	15 (23.40 sq. ft.)	635 lbs.
12" Straight Seatwall Cap, chisled two sides	24 x 12 x 2.25" H	2 sq. ft.	53 lbs.	15 (30 sq. ft.)	845 lbs.
12" Straight Seawall Cap, chisled two sides	24 x 12 x 2.25" H	2 sq. ft.	53 lbs.	15 (30 sq. ft.)	845 lbs.
2-sided Bar Top (Indiana Limestone color only)	36 x 48 x 2.25" H	12 sq. ft.	327 lbs.	1 (12 sq. ft.)	377 lbs.
3-sided Bar Top (Indiana Limestone color only)	36 x 48 x 2.25" H	12 sq. ft.	327 lbs.	1 (12 sq. ft.)	377 lbs.
Fire Ring Cap	10 W x 2.25" H		298 lbs.	8	298 lbs.

SUPER-STIK ADHESIVE

Tube	Item#	Tubes/Case	Pallets
10.5 oz.	1140001	12	108 cases
29 oz.	1140002	12	44 cases

Approximate length of bead by bead diameter:

Tube	1/8" Dia.	1/4" Dia.	3/8" Dia.
10.5 oz.	129 ft.	32 ft.	14 ft.
29 oz.	355 ft.	89 ft.	39 ft.



SNAP-EDGE PAVER RESTRAINT

Item	Length	Item #	Details	Pallets
Paver Edge Restraint	96"	ESEPR96-672	24/bundle	28 bundles
Low Profile	80"	ESELP80-672	24/bundle	28 bundles



GEO-GRID

Item	Item#	Roll Size	Weight	Coverage
Strata Dealer Rolls	1178100	4 x 50'		22.22 sq. yd.
Strata 200	SG460	6 x 300'	95 lbs.	200 sq. yd.
Strata 350	SG450	6 x 300'	100 lbs.	200 sq. yd.



SLEEVE-IT

Sleeve-it is a pre-engineered, wall/fence post anchoring solution.

Item	Item#	Package	Pallet
Sleeve-It	SD1	5 units (1 pkg.)	45 units/pallet

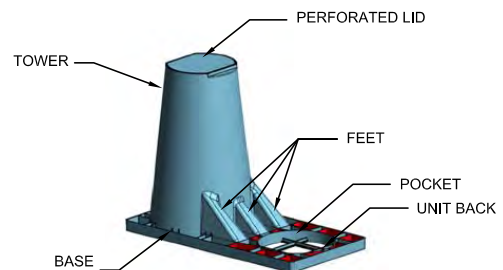

BULLNOSE PAVER

- Smooth surface, full radius front
- Available by layer

Colors: Buff, Brown, Natural, Onyx



Size	Face Area	Weight	Units/Layer	Layers	Units/Pallet	Pallet Weight
12 x 6 x 2-3/8" H	0.50 sq. ft.	13.06 lbs.	48	3	144 (72 sq. ft.)	1,930 lbs.

Dimensions shown are nominal.

BULLET EDGER

- To estimate number of units, divide ln. ft. by 0.9375.
- Available by pallet or layer

Colors: Beechwood, Buff, Carmel, Charcoal, Natural



Size	Unit ln. ft.	Weight	Units/Layer	Layers	Units/Pallet	Pallet Weight
4 x 12.25 x 4" H	0.9375 ln. ft.	14 lbs.	36	5	180 (168.75 ln. ft.)	2,570 lbs.

Dimensions shown are nominal.

CLASSIC EDGER

- Patented T-lock design helps prevent frost heave
- Estimate length, divide lineal ft. by 0.83
- Available by pallet or layer

Colors: Brown, Charcoal, Grey, Red/Black, Sandstone



ROCKWOOD
RETAINING WALLS
A better way.

Size	Unit ln. ft.	Weight	Units/Layer	Layers	Units/Pallet	Pallet Weight
4 x 10 x 2.75" H	0.83 ln. ft.	9 lbs.	48	5	240 (200 ln. ft.)	2,223 lbs.

Dimensions shown are nominal.

TUMBLLED GRANITE EDGER

- Smooth sides, split face, tumbled
- Available by pallet

Colors: Bluestone, Santa Fe, Onyx (new)



Size	Weight	Units/Layer	Layers	Units/Pallet	Pallet	Pallet Weight
12 x 4 x 4" H	16 lbs.	32	5	160	160 ln. ft.	2,610 lbs.

Dimensions shown are nominal.



QUALITY IS OUR STRENGTH

www.alliancegator.com

G2 GATOR MAXX SUPERSAND	Item Number	Package	Min. Qty.	Pallets
G2 Supersand Beige	G2SUPERSAND001B	50 lb. Bag	1	56 bags
G2 Supersand Grey	G2SUPERSAND002G	50 lb. Bag	1	56 bags

SAND

Nitro Sand Beige	GATORNITRO001	40 lb. Pail	1	48 Pails
Nitro Sand Grey	GATORNITRO002	40 lb. Pail	1	48 Pails
Nitro Sand Black	GATORNITRO003	40 lb. Pail	1	48 Pails
Nitro Sand Silver (NEW)	GATORNITRO003	40 lb. Pail	1	48 Pails

GATOR DUST BOND (Large joint application)

Beige	GATOR001	50 lb. Bag	1	56 bags
Grey	GATOR002	50 lb. Bag	1	56 bags

G2 GATOR MAXX BOND

Beige	G2GATORMAXX01	50 lb. Bag	1	56 bags
Grey	G2GATORMAXX02	50 lb. Bag	1	56 bags
Ivory	G2GATORMAXX03	50 lb. Bag	1	56 bags
Black Diamond	G2GATORMAXX04	50 lb. Bag	1	56 bags

BASE

Gator Base	GATORBASE01	10/pkg	1 pkg	12 packages
Gator Base Screws	GATORSCREW001	50/pkg	1 pkg	40 cases (20 pkg's ea.)

BINDERS

Rock Bond (Binder Only)	GATORROCK02	1 gal.	Box (4)	24 boxes /96 gals.
Rock Bond Kit (Binder & Rock)	GATORROCK05	1 pail	1 pail	48 pails/240 gals.

CLEANERS

Efflorescence Cleaner	GATORCLEAN03	1 gal.	Box (4)	24 boxes /96
Efflorescence Cleaner	GATORCLEAN04	5 gal. pail	1 pail	48 pails
Cleaner Shampoo	GATORCLEAN07	1 gal.	Box (4)	24 boxes /96
Cleaner Shampoo	GATORCLEAN08	5 gal. pail	1 pail	48 pails
XP Oil & Grease Remover	GATORCLEAN0212	1 qt.	Box (6)	24 boxes /144
Rust Remover	GATORCLEAN51	1 qt.	Box (6)	24 boxes /144

SOLVENT BASED SEALERS

Seal Satin Look	GATORSEAL06	1 gal.	Box (4)	24 boxes /96
Seal Satin Look	GATORSEAL05	5 gal. pail	1 pail	48 pails
Seal Wet Look	GATORSEAL02	1 gal.	Box (4)	24 boxes /96
Seal Wet Look	GATORSEAL01	5 gal. pail	1 pail	48 pails
Seal Re Sealer	GATORRESEALER02	1 gal.	Box (4)	24 boxes /96
Seal Re Sealer	GATORRESEALER01	5 gal. pail	1 pail	48 pails

WATER BASED SEALERS

Seal Natural Look	GATORSEAL04	1 gal.	Box (4)	24 boxes /96 gals.
Hybrid Enhancer + Low Gloss	GATORHYBRID40	1 gal.	Box (4)	24 boxes /96 gals.
Hybrid Enhancer + Low Gloss	GATORHYBRID41	5 gal. pail	1 pail	48 pails/240 gals.
Seal Natural Stone Enhancer Zero Gloss	GATORSEAL50	1 gal.	Box (4)	24 boxes /96 gals.
Hybrid Enhancer + High gloss	GATORHYBRID45	5 gal. pail		
Hybrid Enhancer + High gloss	GATORHYBRID44	1 gal		
Hybrid Low Gloss	GATORHYBRID03	5 gal. pail		
Hybrid Low Gloss	GATORHYBRID021	1 Gal		
Hybrid High gloss	GATORHYBRID05	5 gal. pail		
Hybrid High gloss	GATORHYBRID04	1 gal		
Natural Look	GATORSEAL03	5 gal. pail		
Natural Stone	GATORSEAL51	5 gal		

CALL FOR PALLET WEIGHTS.

NAILS	Item Number	Package	Min. Qty.	Pallets
Nails Common 10 (180/box)	NAIL COM 10	50 lbs. box	1 box	48 boxes
Nails Common 12 (130/box)	NAIL COM 12	50 lbs. box	1 box	48 boxes
Nails Spiral 10 (250/box)	NAIL SPIR 10	50 lbs. box	1 box	48 boxes
Nails Spiral 12 (210/box)	NAIL SPIR 12	50 lbs. box	1 box	48 boxes

ADHESIVES (Low VOC-black)

Block Bond XP Polyurethane (12 Tubes)	GBBXP 10.3	10.3 oz.	1 case	90/pallet
Block Bond XP Polyurethane (12 Tubes)	GBBXP28	28 oz.	1 case	60/pallet

EDGING

Gator Edge Rigid	GATOREDEGE001	8' length,	24/bundle	672/pallet
Gator Edge Flex	GATORFLEX001	8' length	24/bundle	672/pallet
Gator Edge Mini-Pro	GATOREDEGE003	8' length	24/bundle	384/pallet
Gator Tile Edge	GATOREDEGE007	8' length	24/bundle	384/pallet
Gator Extreme Edge	GATORXTMED1	50 lb. Bag		

CHIPS

Aqua Rock for Permeable Pavers (Granite Grey) GATORAQUA01		50 lbs. bag	1 bag	56 bags
---	--	-------------	-------	---------

G2 GATOR MAXX

- For use in patio, walkway, pool deck and terrace applications
- For use in driveway and motor court applications
- For use in steep slope, street and commercial applications
- Use with concrete pavers, clay pavers and wet cast pavers
- One watering
- 15-minutes rain safe
- Haze free



GATOR BASE

- Acts like a big snowshoe and actually replaces 6" of crushed aggregate base
- Will outperform an aggregate base in freeze/thaw cycles
- Easy to work with... all types of weather, walk on it, slide pavers into place, etc.
- Saves labor, speeds up installation considerably
- Gator Base Screws secure Gator Base's outside perimeter, creating strong lateral support.
- Pedestrian use only



XTREME EDGE

- Great for use in open-graded base applications
- Great for use on flagstone paving applications
- Poly-modified concrete provides flexibility
- Smaller fractured aggregates provide workability
- 3-D matrix fibers expand during mixing and provide durability
- A 50 lb. bag mixes easily and quickly with only a half-gallon of water



NITRO SAND

- Can be applied in wet or dry weather
- Must be applied on wet paving
- Great for open-graded base applications
- Permeable upon installation
- Cures solid within 18 hours
- Leftover sand can be stored for future use

GATOR EDGE

- Use Gator Edge rigid or flexible (1-1/2" profile) in typical paving applications
- Use Gator Edge Mini (1" profile) with natural stone of all types
- Use Gator Tile Edge (5/8" profile) with porcelain tile
- All 3 profiles can be used with Gator Screws for a secure connection on Gator Base

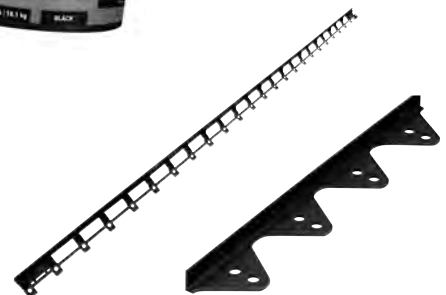

NECESSARIES OUTDOOR LIVING KITS

Necessaries is a collection of affordable, ready-to-assemble outdoor fireplaces, island bars and grills, kitchens, tables, waterfalls, fire rings, seatwalls and pillars kits.

AFFORDABLE LUXURY

Necessaries kits are both beautiful and functional, turning backyards into attractive and enjoyable outdoor living spaces. Also, Necessaries come ready-to-assemble with everything needed to build, making them easier to install and more affordable than typical masonry structures.

EASY TO BUILD

Each Necessaries Outdoor Living Kit comes complete with everything you need to build, including precut block sized to fit, reinforcements, adhesive, and easy-to-read, step-by-step instructions. Most kits can be built by two people in an afternoon, or less.

EXPAND ANYTIME

You can build your project all at once or add new features over time. Because of Necessaries' modularity, expanding your outdoor living space is easy to do whenever you are ready.

EARTHY COLORS

Necessaries kits feature Rockwood Retaining Walls' multi-piece, tumbled Lakeland and Riverland wall systems in: Beechwood, Bluestone, Cascade, Santa Fe.

Convenient standard features

- Easy-to-read, step-by-step instructions
- Rockwood's multi-piece tumbled Lakeland block
- Premium stainless steel grills and components
- Concrete precut and reinforcements sized to fit
- VOC compliant adhesive and gloves
- Mantels, tops and caps are cast from Indiana limestone originals

**KITS CAN BE ORDERED WITH OR WITHOUT TOPS.
KITS CANNOT BE RETURNED!**



GRAND FIREPLACE KITS

Features:

- Includes Majestic Products Villawood 36" stainless steel wood-burning insert, log rack and spark curtain. Adaptable for natural or LP gas.
- 4' stainless stovepipe chimney
- Spark suppressor cap
- Optional Gas burner log set
- Optional **Grand Wood Box Kit** available left or right side
- Optional **Grand Hearth Kit**

Colors: Beechwood, Bluestone, Cascade, Santa Fe

Cap/top Colors: Indiana Limestone, Bluestone

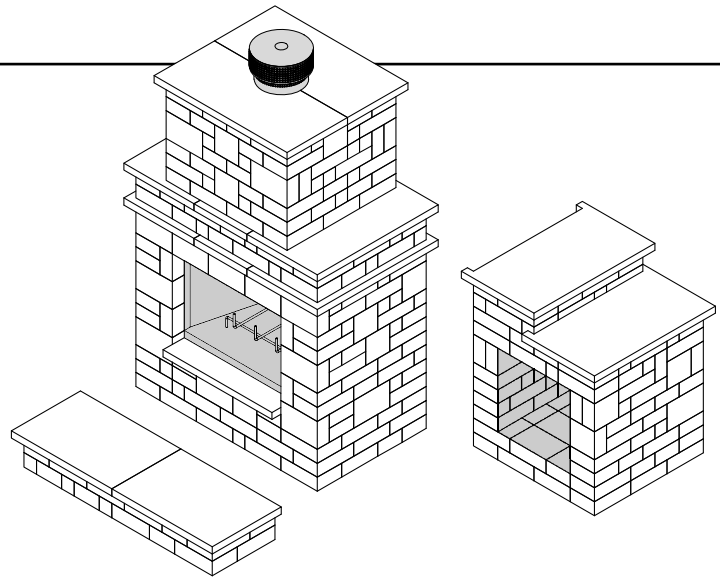

Kit	Dimensions	Pallets - Weight	Build Time
Fireplace (Interior: 33 W x 16 D x 19" H)	60 x 36 x 102" H	5 (9,677 lbs.)	8 hrs.
Hearth	60 x 20 x 10" H	1 (709 lbs.)	3 hrs.
Woodbox (Interior 24 W x 28 D x 24" H)	40 x 36 x 50" H	2 (4,061 lbs.)	1 hr.

Build time assumes two people with limited skills and base work is complete prior to construction. **Kits cannot be returned.**

COLONIAL FIREPLACE KITS

Features:

- 2.25" fire brick protects block
- Optional **Woodbox Kit** available left or right side, optional **Hearth Kit**
- **Gas Burning Option***
 - NG or LP conversion kit, all connections and instructions
 - 2 burner, 52,000/49,000 max Btu's
 - 18" iron log rack, Arizona Weathered Oak ceramic log set

Colors: Beechwood, Bluestone, Cascade, Santa Fe

Cap/top Colors: Indiana Limestone

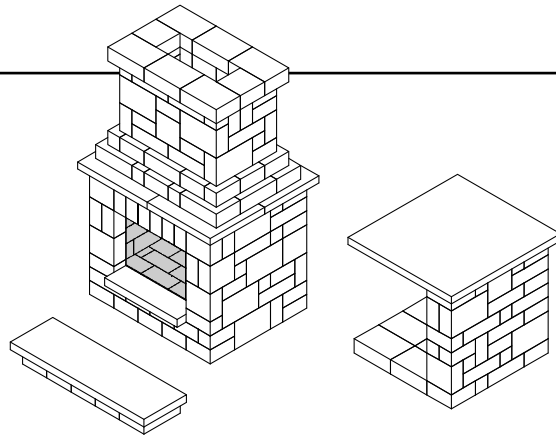

Kit	Dimensions	Pallets - Weight	Build Time
Fireplace (Interior: 29 W x 18.5 D x 26.5" H)	40 x 32 x 70" H	2 (4,360 lbs.)	3 hrs.
Hearth	40 x 12 x 6" H	1 (295 lbs.)	0.5 hr.
Woodbox (Interior: 24 W x 24 D x 28" H)	32 x 32 x 34" H	1 (1,665 lbs.)	1 hrs

COMPACT FIREPLACE KITS

Features:

- 2.25" fire brick protects block
- Optional **Woodbox Kit** available left or right side, optional **Hearth Kit**
- **Gas Burning Option***
 - NG or LP conversion kit, all connections and instructions
 - 2 burner, 52,000/49,000 max Btu's
 - 18" iron log rack, Arizona Weathered Oak ceramic log set

Colors: Beechwood, Bluestone, Cascade, Santa Fe

Cap/top Colors: Indiana Limestone

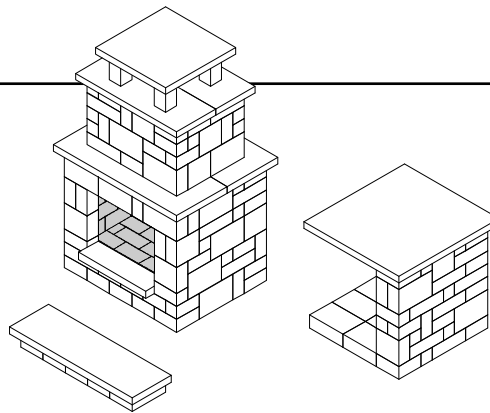

Kit	Dimensions	Pallets - Weight	Build Time
Fireplace (Interior: 29 W x 18.5 D x 26.5" H)	40 x 32 x 70" H	2 (3,735 lbs.)	3 hrs.
Hearth	40 x 12 x 6" H	1 (295 lbs.)	0.5 hr.
Woodbox (Interior: 24 W x 24 D x 28" H)	32 x 32 x 34" H	1 (1,665 lbs.)	1 hrs.

VICTORIAN FIREPLACE KITS

Features:

- 2.25" fire brick protects block
- Optional **Woodbox Kit** available left or right side, optional **Hearth Kit**
- **Gas Burning Option***
 - NG or LP conversion kit, all connections and instructions
 - 2 burner, 52,000/49,000 max Btu's
 - 18" iron log rack, Arizona Weathered Oak ceramic log set

Colors: Beechwood, Bluestone, Cascade, Santa Fe

Cap/top Colors: Indiana Limestone

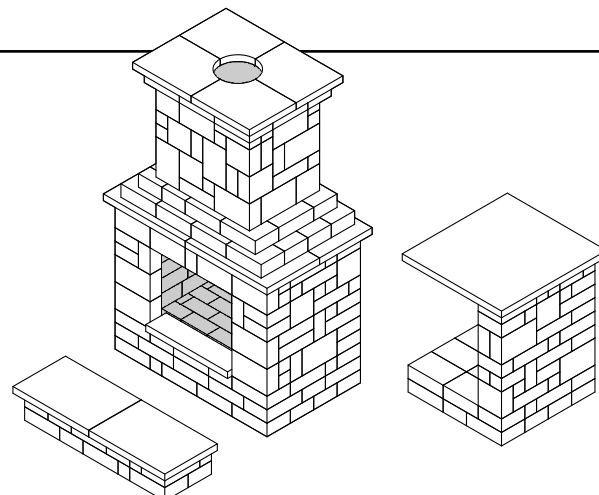

Kit	Dimensions	Pallets - Weight	Build Time
Fireplace (Interior: 31 W x 17.5 D x 29.5" H)	52 x 32 x 89" H	5 (6,610 lbs.)	8 hrs.
Hearth	52 x 18 x 10" H	1 (580 lbs.)	1 hr.
Woodbox (Interior: 24 W x 24 D x 32" H)	32 x 32 x 42" H	2 (2,190 lbs.)	3 hrs.

Build time assumes two people with limited skills and base work is complete prior to construction. **Kits cannot be returned.**

FIRE RING KITS

GRAND FIRE RING KIT:

- One-piece, heavy gauge, 48" D x 12" H Solid steel insert protects block (30.5" interior dia. x 8" H, 1.5" flang)
- Optional **Fire Ring Block Layer** – add layers to increase height
- Optional **Fire Ring Cap** – chiseled edge, eight-piece, in three colors, 2.25" H
- Optional **Swivel Cooking Grate** – removable, heavy steel construction, ADA compliant
- Optional **E-Z Access Spark Screen** – keep ash/sparks inside and debris out, hinged for easy access
- Optional **Cover** – heavy galvanized steel with or without cooking grate slot

Colors: Beechwood, Bluestone, Cascade, Santa Fe

GRAND GAS FIRE RING KIT:

- Push-button electronic ignition
- 65,000 max Btu/hr, natural gas or LP
- Thermo-couple auto shut-off safety feature
- #304 stainless steel construction
- All connections and fittings preassembled
- 50 lbs. lava rock
- Optional **Fire Ring Cap** – chiseled edge, eight-piece, in three colors, 2.25" H
- Optional **Arizona Weathered Oak Log Set**



Colors: Beechwood, Bluestone, Cascade, Santa Fe

VICTORIAN FIRE PIT KIT:

- Four-piece, heavy gauge, solid steel insert protects block
- Optional **Swivel Cooking Grate**

Colors: Beechwood, Bluestone, Cascade, Santa Fe

BARN PLANK WALL FIRE PIT KIT:

- Four-piece, heavy gauge, solid steel insert protects block
- Optional **Swivel Cooking Grate**

Colors: Mahogany, Weathered Grey

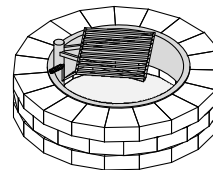

Grand Fire Ring

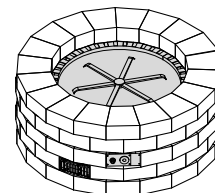

Grand Gas Fire Ring

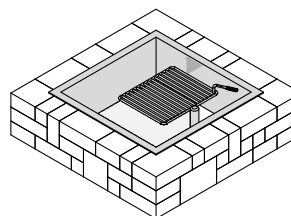

Victorian Fire Pit

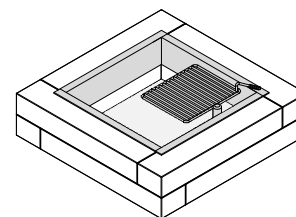

Barn Plank Wall Fire Pit

Fire Ring/Pit	Dimensions	Pallets - Weight	Build Time	Details
Grand (block only)	48 x 12" H	1 (1,019 lbs.)	0.5 hr.	Without steel insert
Grand Fire Ring	48 x 12" H	1 (1,057 lbs.)	0.5 hr.	With steel insert
Grand Fire Ring	48 x 12" H	1 (1,085 lbs.)	0.5 hr.	With insert and swivel cooking grate
Grand (one layer)	48 x 4" H	1 (346 lbs.)	-	19 Lakeland Fire Ring Block
Victorian Fire Pit (block only)	48" W x 12" H	1 (1,285 lbs.)	0.5 hr.	Without steel insert
Victorian Fire Pit	48" W x 12" H	1 (1,310 lbs.)	0.5 hr.	With insert and swivel Cooking Grate
Grand Gas Fire Ring	48 x 20" H	1 (1,710 lbs.)	0.5 hr.	Natural Gas
Barn Plank Wall Fire Pit	48 x 12" H	1 (1,255 lbs.)	0.5 hr.	With steel insert
Barn Plank Wall Fire Pit	48 x 12" H	1 (1,525 lbs.)	0.5 hr.	With steel insert and swivel cooking grate

Options/Accessories	Dimensions	Weight	Details
Fire Ring Cap (Cannot be double stacked)	10 W x 2.25" H	298 lbs.	In Indiana Limestone, Bluestone, or Buff
Grand Cover	37.9 dia. x 2.88" H	27 lbs.	Heavy galvanized steel
Grand Cover w/Slot	34.9 dia. x 1.88" H	27 lbs.	Heavy galvanized steel, slotted for swivel cooking grate
Grand Swivel Cooking Grate	19.25 x 17.5 x 2" H	10 lbs.	300 sq. in. ADA approved swivel cooking grate, removable
Grand Steel Ring Insert	33.5 x 33.5 x 8.5" H	34 lbs.	Solid 10-gauge steel with 1" top lip, boxed
E-Z Access Spark Screen	40 x 18" H	22 lbs.	Hinged spark screen
LP Gas Conversion Kit (Grand Gas Fire Ring Only)			O-Ring conversion to LP
AZ Weathered Oak Gas Log Set	16" H	36 lbs.	9 pc. 16" height of log stack
Victorian Swivel Cooking Grate	19.25 x 17.5 x 2" H	10 lbs.	300 sq. in. ADA approved swivel cooking grate, removable
Victorian Steel Insert	33.5 x 33.5 x 8.5" H	34 lbs.	Solid 10-gauge steel with 1" top lip, boxed

Build time assumes two people with limited skills and base work is complete prior to construction. Kits cannot be returned.

SEATWALL AND PILLAR KITS

a) 20" PILLAR KIT:

- 2.25" H chiseled cap

b) 20" PILLAR WITH GLASS KIT: (lights not included)

- Pittsburgh Corning Premiere 8" glass block
- 2.25" H chiseled cap

c) 24" PILLAR KIT:

- 2.25" H chiseled cap

d) LAKELAND SEATWALL KIT:

- Creates a 6' straight wall
- Optional chiseled cap

e) RIVERLAND SEATWALL KIT:

- Creates an 8' radius wall
- Optional chiseled cap

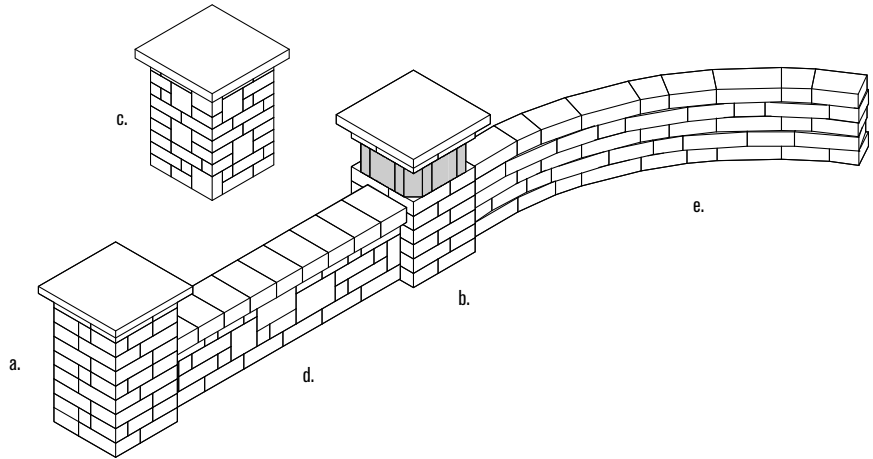

Colors: Beechwood, Bluestone, Cascade, Santa Fe

Cap/top Colors: Indiana Limestone, Bluestone

Kit	Dimensions	Pallets - Weight	Build Time
20" Pillar Kit (w/25 x 25 x 2.25" top)	20 x 20 x 38" H	1 (1,260 lbs.)	0.5 hr.
20" Pillar w/Glass (w/25 x 25 x 2.25" top)	20 x 20 x 38" H	1 (1,150 lbs.)	0.5 hr.
24" Pillar Kit (w/30 x 30 x 2.25" top)	24 x 24 x 39" H	1 (1,665 lbs.)	0.5 hr.
Lakeland Seatwall Kit	72 x 8 x 20" H	1 (1,075 lbs.)	0.5 hr.
Riverland Seatwall Kit	108 x 8 x 20" H	1 (1,400 lbs.)	0.5 hr.

WOODBBOX/STAND KITS

Woodbox/stands are ideal for table top grills and pizza ovens.

Colors: Beechwood, Bluestone, Cascade, Santa Fe

Cap/top Colors: Indiana Limestone, Bluestone

Kit	Dimensions	Pallets/Weight	Build Time
a) Silver Creek Chiseled Edge Top	36 x 32 x 34" H	1 Pallet: (7,271 lbs.)	1 hr.
b) Granite Top (Kitchen Kit)	32 x 28 x 37" H	1 Pallet: (1,830 lbs.)	1 hr.

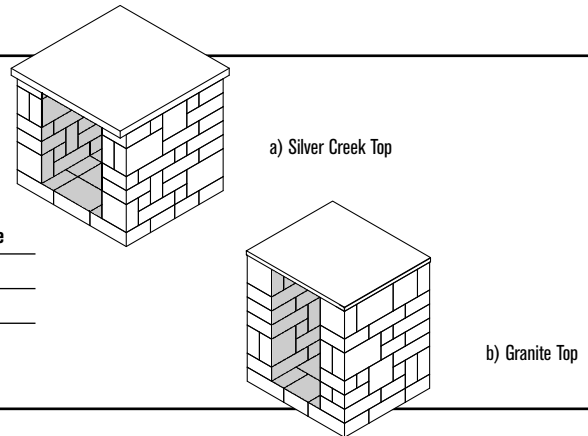

WATERFALL KITS

GRAND WATERFALL KIT:

- 1,350 gph mag drive pump
- 48" half-round basin
- 23" stainless steel spillway
- Kits include all plumbing/connections
- Optional LED light kit; blue or white

COMPACT WATERFALL KIT:

- 850 gph mag drive pump
- 26" square basin
- 11" stainless steel spillway
- Optional LED light kit; blue or white

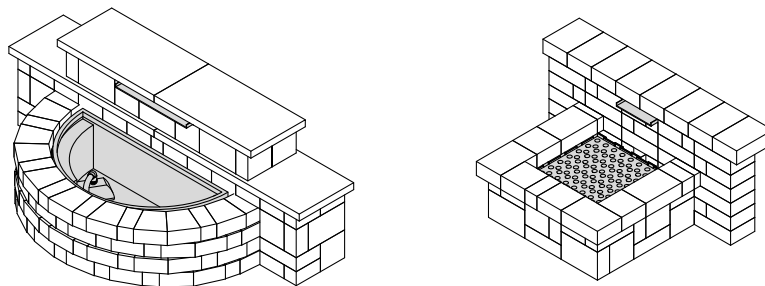

Colors: Beechwood, Bluestone, Cascade, Santa Fe

Cap/top Colors: Indiana Limestone, Bluestone

Kit	Dimensions	Pallets/Weight	Build Time
Grand Water Feature	98" x 48" x 32" H	3 (3,475 lbs.)	4 hrs.
Compact Water Feature	64" x 40" x 28" H	1 (1,660 lbs.)	3 hrs.

Build time assumes two people with limited skills and base work is complete prior to construction. **Kits cannot be returned.**

GRAND ISLAND BAR SERIES KITS

a) GRAND ISLAND BAR/GRILL WITH STORAGE KIT:

- Summerset Sizzler Pro 32" grill*
- Stainless steel double doors - vented

b) GRAND ISLAND BAR/GRILL WITH REFRIGERATOR OPENING KIT:

- Summerset Sizzler Pro 32" grill*
- Stainless steel double doors - vented
- 24" x 36" x 28" H opening

***SUMMERSET SIZZLER PRO GRILLS:**

- #443 and 304 stainless steel construction
- Push-to-turn knob ignition 3" Heat Indicator
- 14,000 BTU #304 cast stainless steel burners
- 15,000 BTU infrared back burner
- Natural gas or propane fuel
- Double-lined hood assures optimal airflow
- 8mm cooking grates won't warp or rust
- Easy-clean briquette system for even heat
- 30" double stainless doors
- LED exterior lights
- Heat zone separators
- Twin Interior cooking lights



Deluxe Rotisserie: (optional)

- #304 stainless steel, heavy-duty motor and 25 lb. capacity
- *Pro Sizzler features and rotisserie require 120 volt electrical

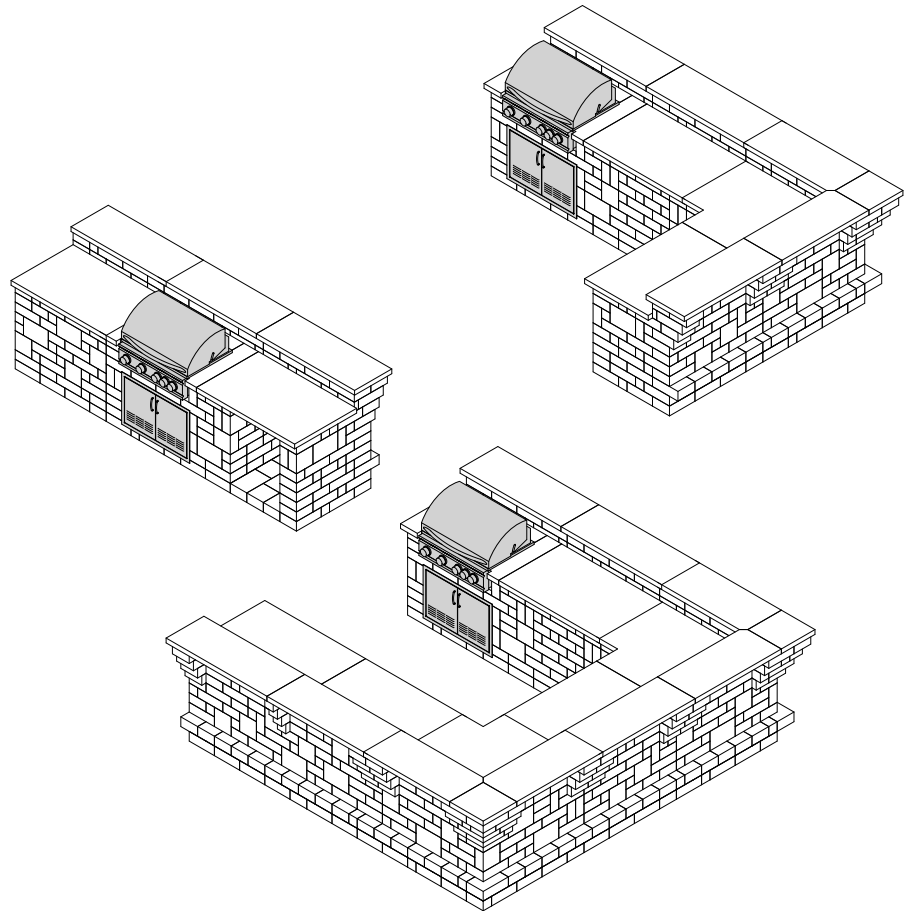

c) GRAND ISLAND BAR 8' KIT

d) GRILL SURROUND KIT: For standing grills, 60" opening

e) CORNER RETURN KIT*:** Makes L-shaped bar/grill

f) BAR SECTION 4' KIT:** Left or right facing

Colors: Beechwood, Bluestone, Cascade, Santa Fe

Cap/top Colors: Indiana Limestone, Bluestone

GRAND ISLAND KITS ARE MODULAR AND CAN BE BUILT IN ANY CONFIGURATION IMAGINABLE.

Kit	Dimensions	Pallets/Weight	Build Time
Grand Island Bar	96 x 48 x 46" H	3 (7,271 lbs.)	6 hr.
Grand Island Bar w/Grill & Storage* (w/32" Pro Sizzler grill)	96 x 48 x 46" H	4 (7,341 lbs.)	7 hr.
Grand Island Bar w/Grill & Refrigerator Opening (w/32" Pro Sizzler grill)	96 x 48 x 46" H	4 (7,341 lbs.)	7 hr.
Grand Island Grill Surround (Fits 60" freestanding grill)	96 x 48 x 46" H	2 (4,915 lbs.)	4 hr.
Bar Section 4' Section**	48 x 48 x 46" H	1 (3,780 lbs.)	4 hr.
Grand Island Bar Corner Return***	48 x 48 x 46" H	2 (5,140 lbs.)	6 hr.

*Please designate LP or NG grill at time of order. ** Must specify left side or right side when ordering. *** Corner return edges are not finished, cannot use alone.

**KITS CAN BE ORDERED WITH OR WITHOUT TOPS.
KITS CANNOT BE RETURNED!**



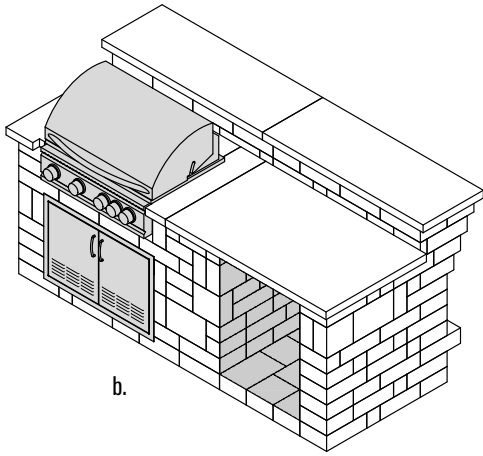

b.

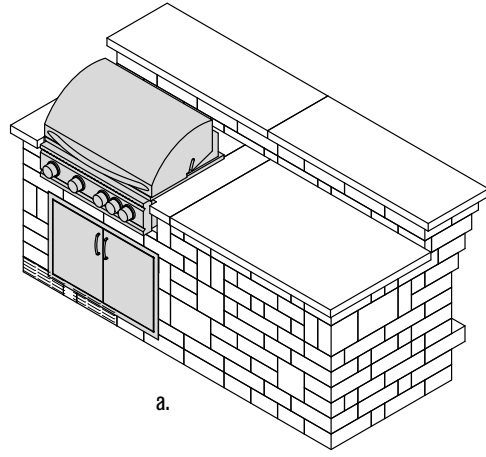

a.

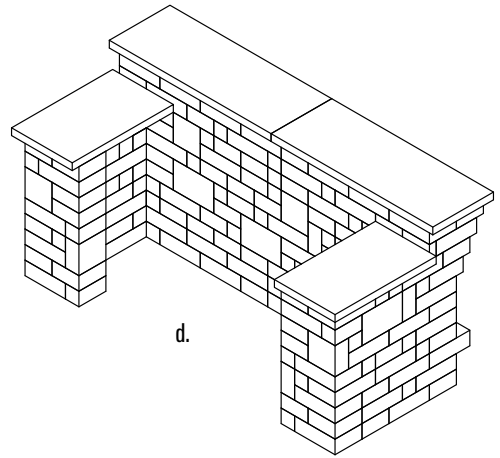

d.

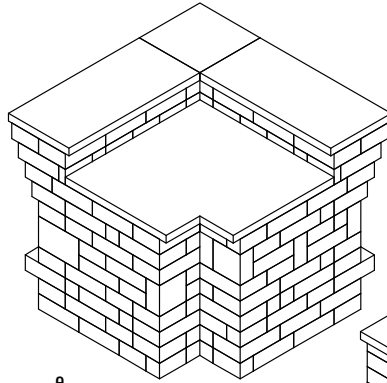

e.

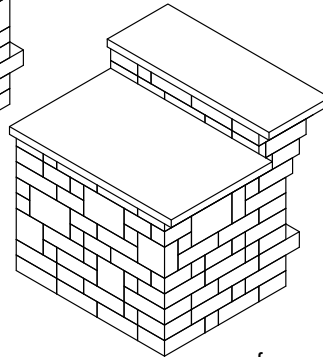

f.

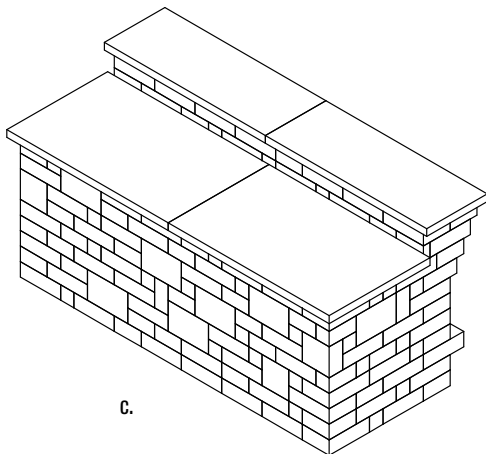

c.

CONTEMPORARY OUTDOOR LIVING KITS

STANDARD FEATURES:

- Easy-to-read, step-by-step instructions
- Rockwood's Contemporary Wall block
- Concrete precut and reinforcements sized to fit
- VOC-compliant adhesive and construction gloves



CONTEMPORARY ISLAND BAR/GRILL:

- Summerset Sizzler Pro 32" stainless grill with cover
- Stainless steel, vented double doors and paver vent kit
- Three-piece, 3cm black pearl granite top
- LP or nat. gas fuel



CONTEMPORARY WOOD BURNING FIRE PIT:

- Four courses (Beechwood or Cascade) + Onyx band
- Heavy-gauge, four-piece steel insert
- Optional, removable swivel cooking grate
- Optional Contemporary Wall Cap (in Cascade or Onyx)



CONTEMPORARY GAS BURNING FIRE TABLE:

- Four corner/pillar block courses (Beechwood or Cascade) + Onyx band
- Contemporary Wall Cap (Onyx)
- Firegear's stainless steel drop-in pan and connections (100,000 max Btu)
- Piloted thermocouple safety valve, manual spark ignitor, lava rock and vent kit
- LP or nat. gas fuel



CONTEMPORARY GAS BURNING FIRE PIT:

- Four courses (Beechwood or Cascade) + Onyx band
- Contemporary Wall Cap (Onyx)
- Firegear's stainless steel drop-in pan and connections (150,000 max Btu)
- Piloted thermocouple safety valve, manual spark ignitor, lava rock and vent kit
- LP or nat. gas fuel

CONTEMPORARY FIREPLACE KIT:

- With protective firebrick
- In Beechwood or Cascade + Onyx bands
- 2.5" H Silver Creek chisled mantels/tops
- Optional Hearth (one pallet, 600 lbs.)
- Optional Woodbox kit



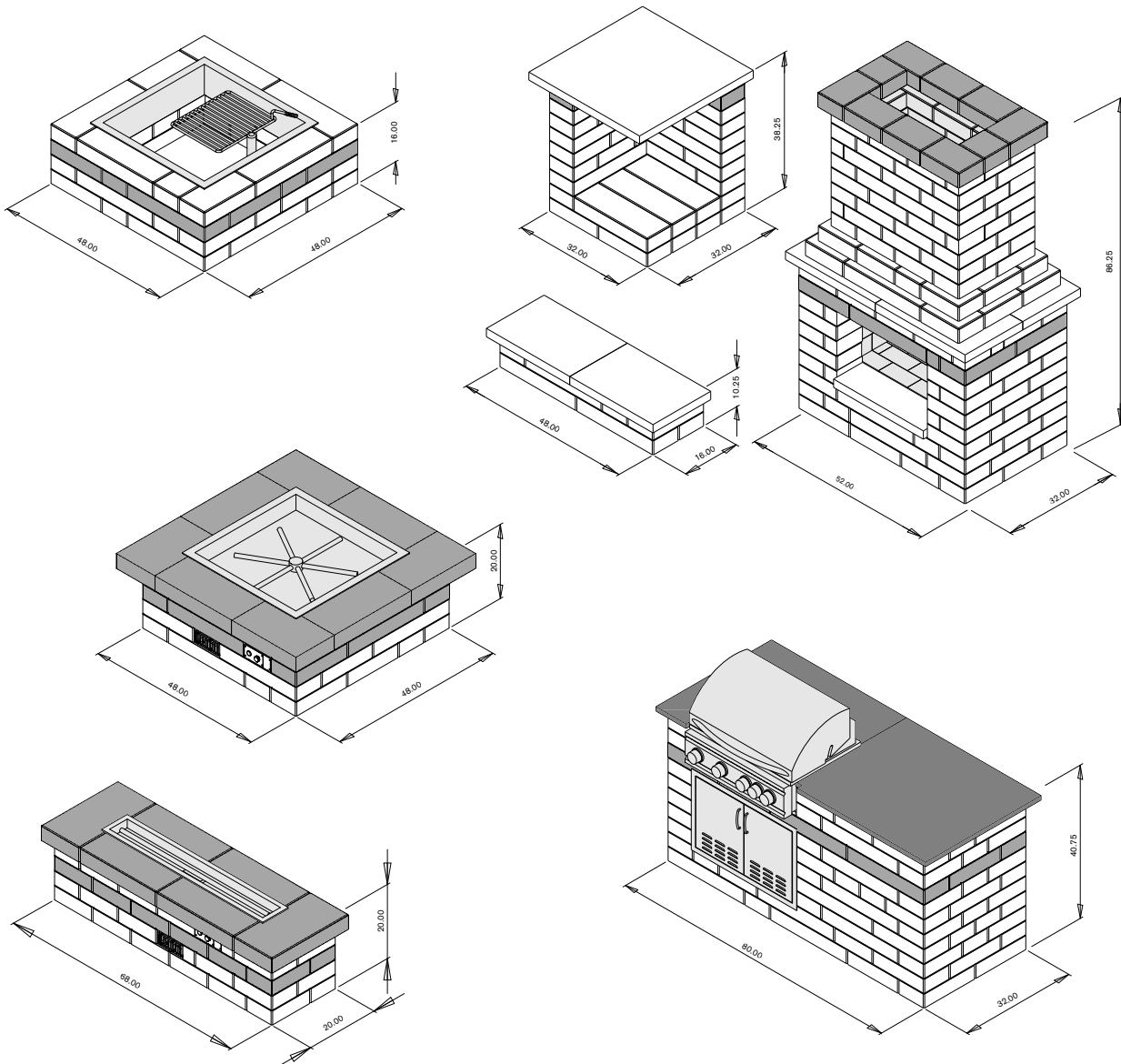

Kit	Pallets	Weight	Notes
Fire Pit	1	1,690 lbs.	4-piece steel insert
Fire Pit w/Grate	1	1,705 lbs.	Removable swivel cooking grate, 4-piece steel insert
Optional Fire Pit Cap	1	450 lbs.	Contemporary Cap block (Onyx)
Gas Fire Pit	1	2,115 lbs.	Stainless burner/insert, vent kit. Specify LP or NG fuel
Gas Fire Table	1	2,050 lbs.	Stainless burner/insert, vent kit. Specify LP or NG fuel
Island Grill	4	5,860 lbs.	32" Sizzler Pro drop-in grill, cover, Black Pearl granite top, stainless double doors
Fireplace	4/5	9,136 lbs.	Protective firebrick, Silver Creek chiseled mantel/tops
Woodbox	1	1,930 lbs.	Silver Creek chiseled top
Hearth	1	600 lbs.	Silver Creek chiseled top



KITS CANNOT BE RETURNED!

KITCHEN CABINET KITS

Features:

- Easy-to-read, step-by-step instructions
- Premium stainless steel grills and components
- Concrete precut and reinforcements sized to fit
- VOC-compliant adhesive and gloves
- High-grade, 3cm Solid Granite Tops in Black Pearle or Viscon White



Colors: Beechwood, Bluestone, Cascade, Santa Fe

SEE PAGE 47 FOR KITCHEN DRAWINGS

Kit	Dimensions	Pallets	Weight	Build Time
40" Sizzler Pro Grill Cabinet (5 burner) Summerset Sizzler Pro 40" Grill, 30" vented double doors, grill cover, 12,000 max Btu	56 x 28 x 37" H	2	2,890 lbs.	6 hrs.
32" Sizzler Pro Grill Cabinet (4 burner) Summerset Sizzler Pro 32" Grill, 30" vented double doors, grill cover, 12,000 max Btu	48 x 28 x 37" H	2	2,535 lbs.	5 hrs.
Side Burner Cabinet #304 stainless steel construction. Push-to-turn knob ignition, easy-glide drawers, 30,000 Btu/hr solid brass burners. 19.5" x 10.5" cooking surface.	32 x 28 x 37" H	2	1,905 lbs.	4 hrs.
Prep Center Cabinet Double drawer/door combo.	48 x 28 x 37" H	2	2,270 lbs.	5 hrs.
Prep Center Cabinet w/Sink Double drawer/door combo, sink and fixture.	48 x 28 x 37" H	2	2,295 lbs.	6 hrs.
Refrigerator Cabinet	32 x 28 x 37" H	1	1,035 lbs.	4 hrs.
Two Drawer Cabinet Easy-glide stainless steel drawers. Fully enclosed stainless steel outside.	32 x 28 x 37" H	2	1,985 lbs.	5 hrs.
Trash Cabinet Easy-glide pullout drawer. Accommodates a 12-gallon trash can.	28 x 28 x 37" H	2	1,110 lbs.	3 hrs.
Smoker Cabinet (smoker not available or included)	40 x 28 x 37" H	1	2,120 lbs.	4 hrs.
Woodbox/Stand Cabinet	32 x 28 x 37" H	1	1,830 lbs.	4 hrs.
Corner Cabinet	28 x 28 x 37" H	1	1,935 lbs.	4 hrs.
Island Cabinet Double drawer/door combo. Base size 65 W x 32.50" D.	90 x 45.5 x 37" H	4	4,320 lbs.	8 hrs.
Island Cabinet w/Sink Double drawer/door combo, sink and fixture.	90 x 45.5 x 37" H	4	4,335 lbs.	9 hrs.
Deluxe Rotisserie Kit (optional) #304 stainless steel, heavy-duty motor, 25 lb. capacity.				
Grill Cover (replacement)				

Build time assumes two people with limited skills and base work is complete prior to construction. Kits cannot be returned.

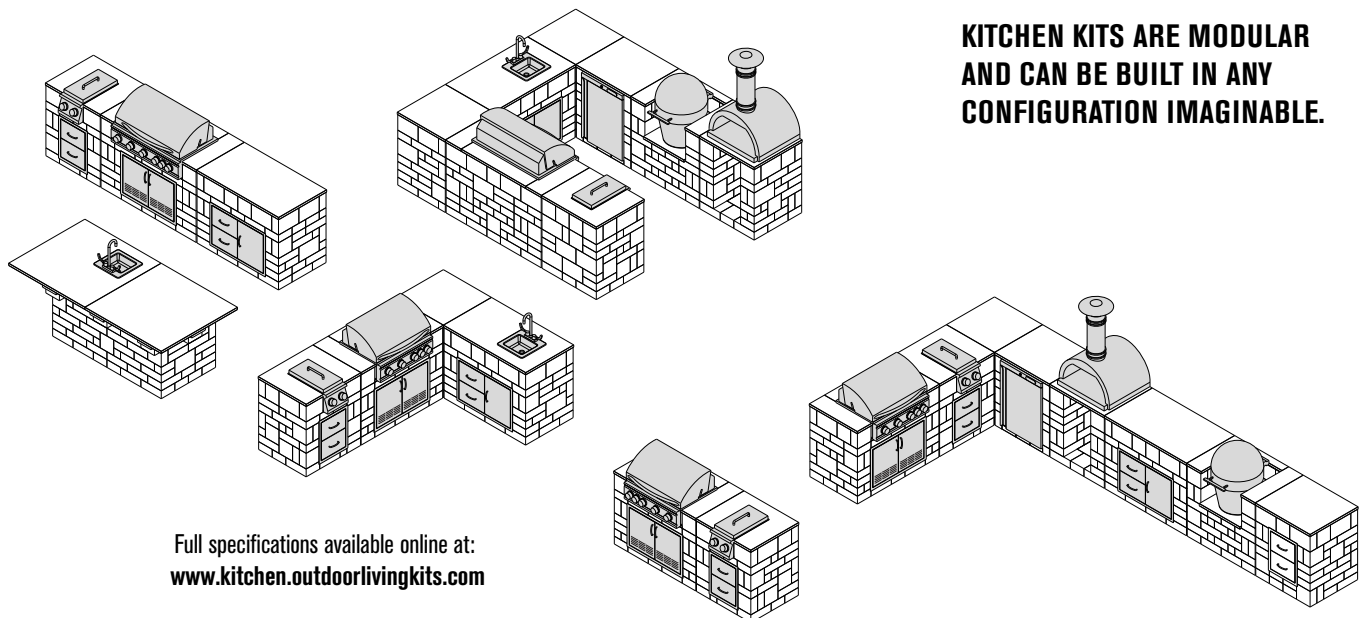

KITCHEN KITS ARE MODULAR AND CAN BE BUILT IN ANY CONFIGURATION IMAGINABLE.

Full specifications available online at:
www.kitchen.outdoorlivingkits.com

SUMMERSET SIZZLER PRO GRILLS



Elegant, functional and affordable, these quality components and cabinets are ready to assemble in any configuration you can imagine.

Affordable luxury

The Kitchen by Necessaries is beautiful, functional and turns backyards into attractive and enjoyable outdoor living spaces. These cabinets come ready to assemble making them easier to install and more affordable than typical masonry structures.

Easy to build

The Kitchen is a series of individual cabinet kits that come complete with everything needed to build, including precut block and granite tops sized to fit, reinforcements, adhesive, and easy-to-read, step-by-step instructions. Depending on the complexity, most kitchens can be built in a day or less.

Expand at anytime

Build your Kitchen all at once or add new features over time. Because of their modularity, expanding your outdoor cooking and entertaining space is easy to do at any time.

Earthy colors

The Kitchen features Rockwood Retaining Walls' multi-piece, tumbled Lakeland wall block. Its linear design and aged appearance fit well in landscapes of any style or decor.

Convenient standard features

- Easy-to-read, step-by-step instructions
- Rockwood's multi-piece tumbled Lakeland block
- Premium stainless steel grills and components
- High-grade 3cm granite tops
- Concrete precut and reinforcements sized to fit
- VOC compliant adhesive and gloves

Kitchen Grill Kits feature Summerset Sizzler Pro Grills with features that every backyard chef will love.

Summerset Sizzler Pro Grills:

- #443 and 304 stainless steel construction
- Push-to-turn knob ignition 3" Heat Indicator
- 14,000 BTU #304 cast stainless steel burners
- 15,000 BTU infrared back burner
- Natural gas or propane fuel
- Double-lined hood assures optimal airflow
- 8mm cooking grates won't warp or rust
- Easy-clean briquette system for even heat
- 30" double stainless doors
- LED exterior lights
- Heat zone separators
- Twin Interior cooking lights

Deluxe Rotisserie: (optional)

- #304 stainless steel, heavy-duty motor and 25 lb. capacity
- Pro Sizzler features and rotisserie require 120 volt electrical



SUMMERSET

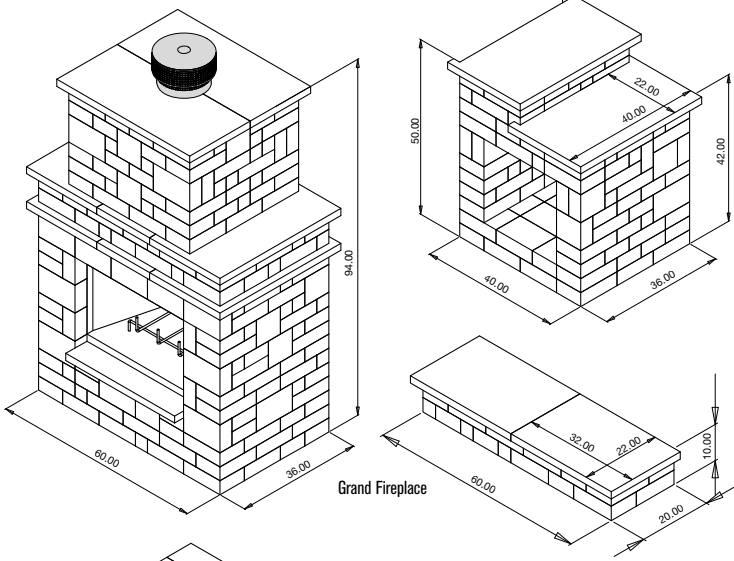

Grand Fireplace

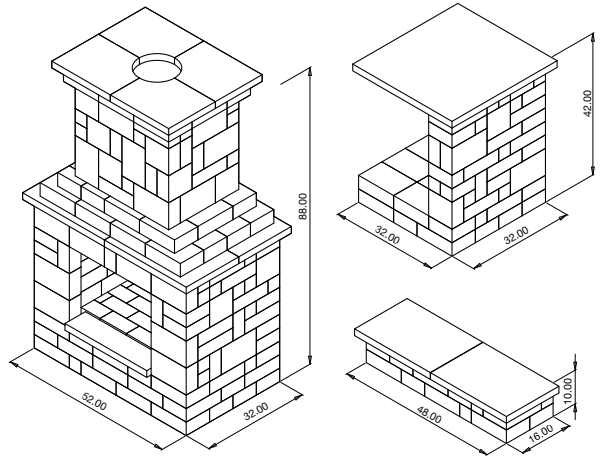

Victorian Fireplace

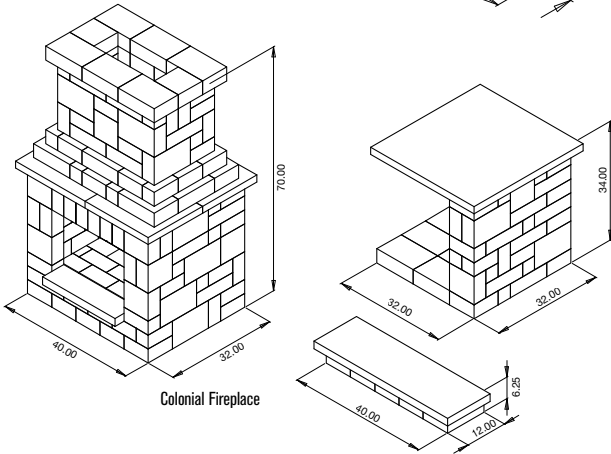

Colonial Fireplace

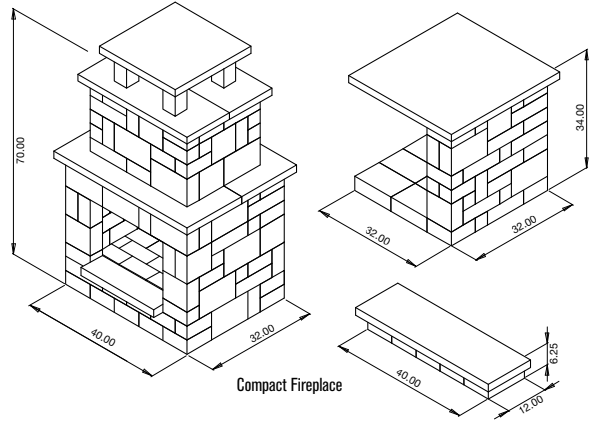

Compact Fireplace

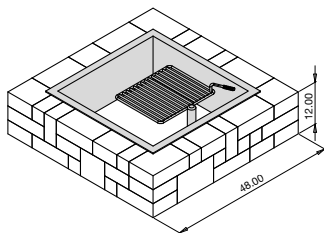

Victorian Fire Pit

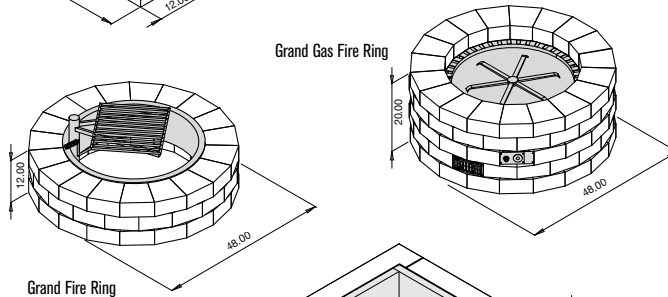

Grand Gas Fire Ring

Grand Fire Ring

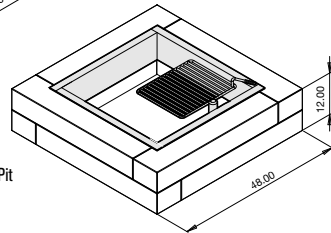

Barn Plank Wall Fire Pit

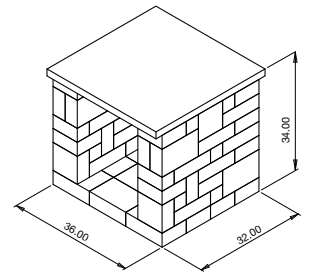

Woodbox/Stand

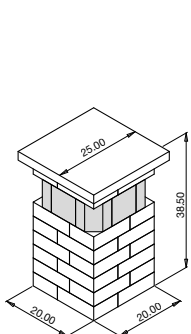

20" Pillar w/ Glass

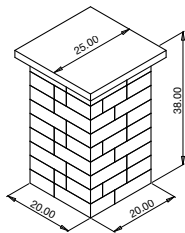

20" Pillar

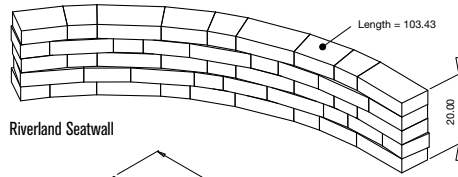

Riverland Seatwall

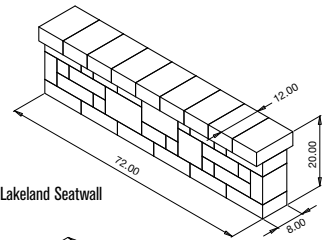

Lakeland Seatwall

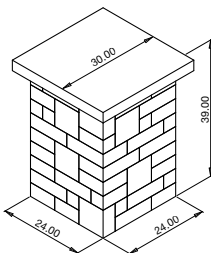

24" Pillar

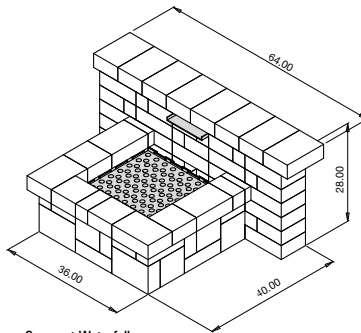

Compact Waterfall

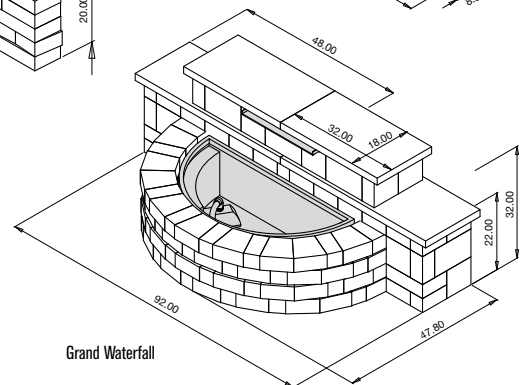

Grand Waterfall

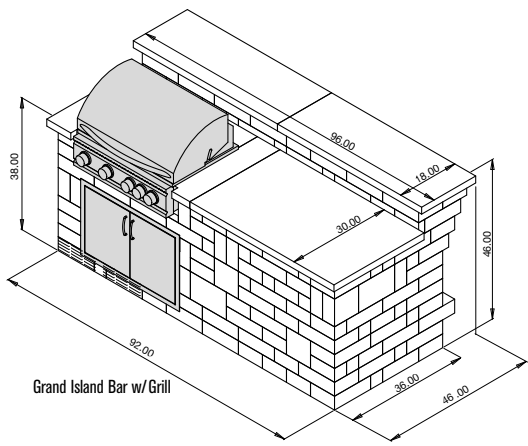

Grand Island Bar w/Grill

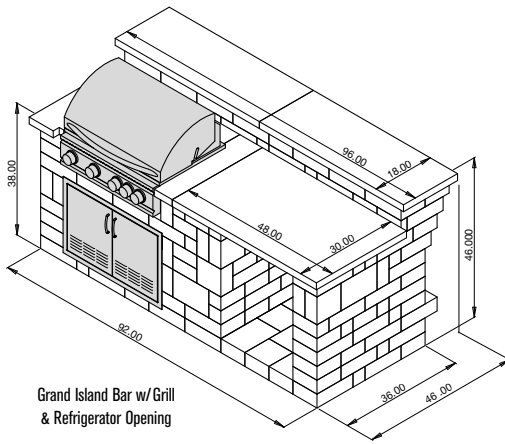

Grand Island Bar w/Grill & Refrigerator Opening

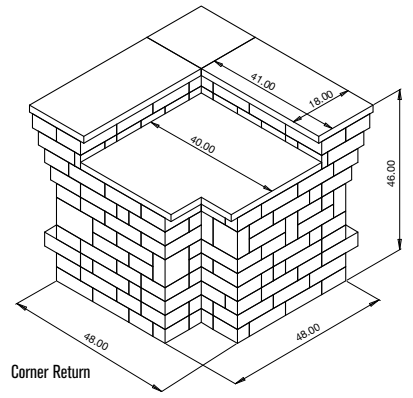

Corner Return

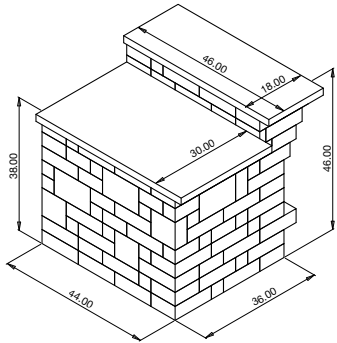

4' Bar Extension

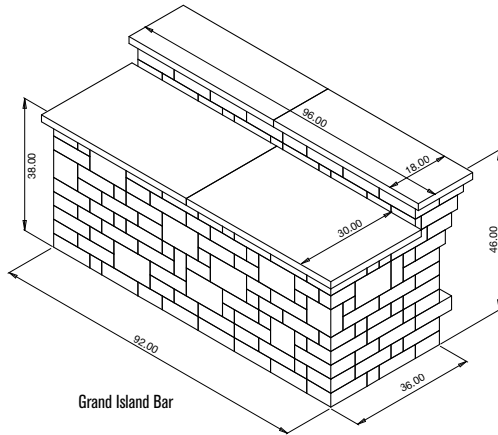

Grand Island Bar

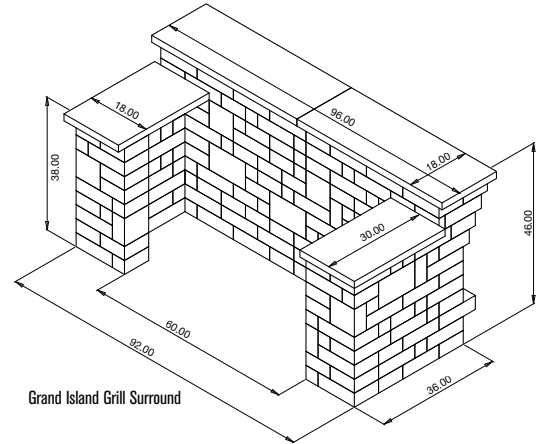

Grand Island Grill Surround

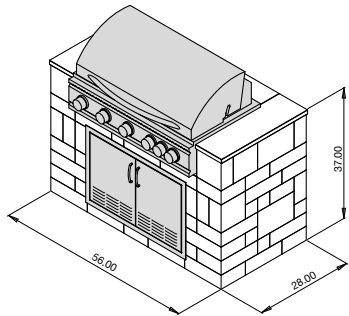

40" Sizzler Grill Cabinet

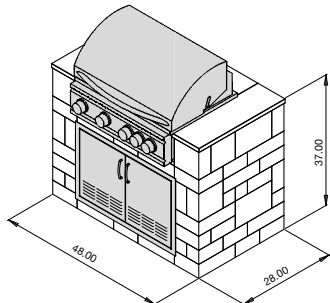

32" Sizzler Grill Cabinet

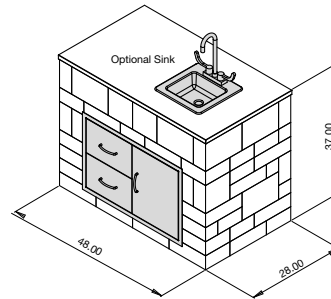

Prep Station Cabinet

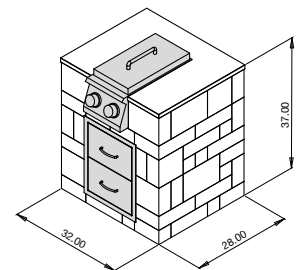

Side Burner Cabinet

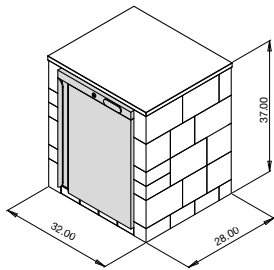

Refrigerator Cabinet

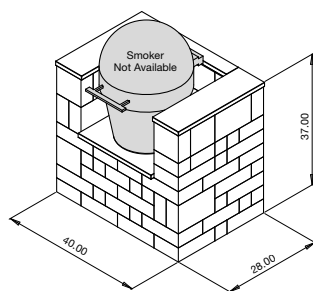

Smoker Cabinet

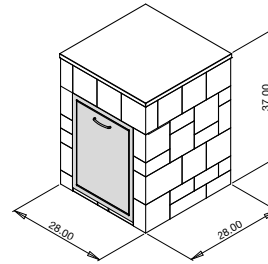

Trash Cabinet

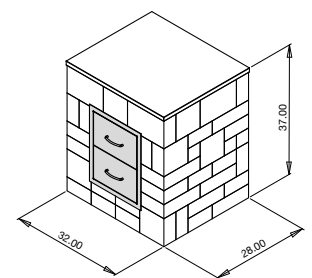

Two Drawer Cabinet

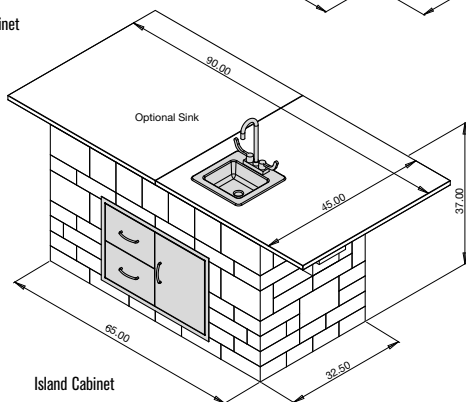

Island Cabinet

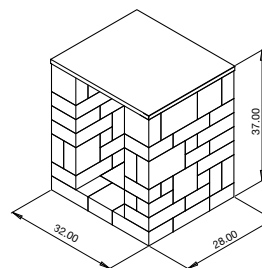

Woodbox/Stand Cabinet

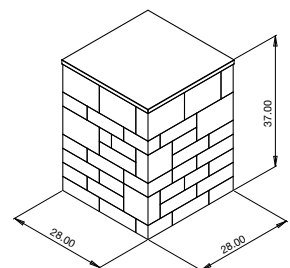

Corner Cabinet

PAVER MATERIAL CALCULATOR

EXCAVATION DEPTH GUIDE: Gravel Base: Use minimum depths in a well-drained area or undisturbed soil. Use maximum depths in poorly drained area or disturbed soil. ½" less is required to compensate compacting of pavers. If soil is saturated more than 50% of the time, filter fabric and extra base should be used.

	Pedestrian Traffic	Light Vehicular Traffic
Pavers	2-3/8"	2-3/8"
Sand	1"	1"
Gravel Base (compacted)	4" - 6"	8" - 12"
Total Excavation Depth	7" - 9"	11" - 15"

BASE MATERIAL CALCULATOR: **Granular Base:** Square Footage of Pavers (x) (depth of base ÷ 12) ÷ 27 = Cubic Yards of Base Needed
Bedding Sand (1" depth): Square Footage of Pavers (x) 0.0031 = Cubic Yards of Sand Needed

RETAINING WALL MATERIAL CALCULATOR

Use the following methods to estimate the amount of base material, drainage rock, and adhesive needed.

BASE MATERIAL CALCULATOR: A typical trench is 2' wide X 14" deep to bury a full course of 8" block. Base material must be a minimum of 6" in height.

$$\frac{\text{Wall Length in ft.}}{\text{Base Height in ft.}} \times \frac{\text{Base Width in ft.}}{27} = \text{Cubic Yards}^* \quad \text{*Add 10\% for inconsistencies in the trench and compaction.}$$

DRAINAGE ROCK CALCULATOR: You need enough drainage rock to fill 1' behind the tail of the block and to fill any cores.

$$\frac{\text{Wall sq. ft.}}{1.33} \div 27 = \text{Cubic Yards}$$

ADHESIVE CALCULATOR: Adhesive required depends on block type and construction. Use the guide below to estimate the amount of adhesive required.

Approximate length of bead by width:

Tube Size	Bead Widths/Tube		
	1/8"	1/4"	3/8"
10.5 oz.	129 ft.	32 ft.	14 ft.
29 oz.	355 ft.	89 ft.	39 ft.

ONLINE CALCULATOR

Quickly and easily calculate paver and materials requirements from your desktop or mobile device. Send yourself a PDF of the results for your project planning.

Go to: <https://rochesterpc.com/estimator/>

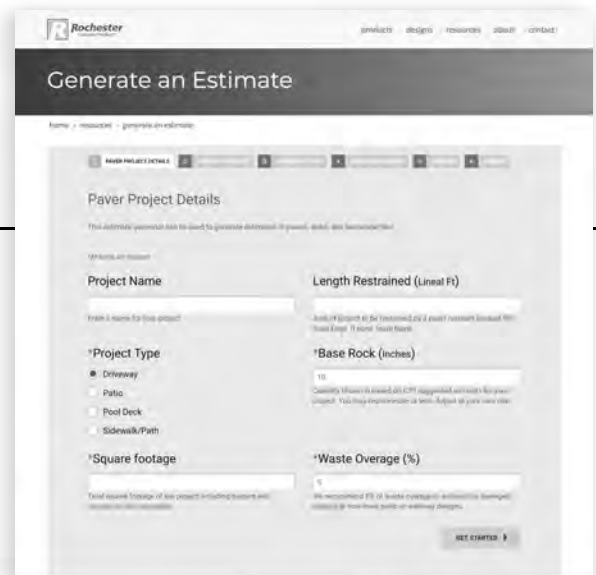

POLICIES, CREDIT TERMS AND CONDITIONS

ORDERING POLICY:

Purchase orders must be faxed or entered on-line:

Dispatch Fax Numbers:

- Rochester: (507) 424-4697 or (507) 288-1487
- Beaver Dam: (920) 386-4612 or (920) 386-9054
- Jordan: (952) 492-3668

DISPATCH/YARD HOURS:

- April 1 – Oct. 31: 7:30 a.m. - 5:00 p.m.
- Nov. 1 – Mar. 14: 8:00 a.m. - 3:30 p.m.

ORDER ON-LINE:

- <http://order.rochesterpc.com/>
- Upon receipt of an order, buyer will receive an Order Acknowledgment with order details and costs. Unless changes are communicated to dispatch, orders will be processed and invoiced as shown on the Order Acknowledgment.
- The acceptance of an order by RCP shall constitute a binding contract of purchase and sale in accordance with the terms and conditions stated in this agreement.
- All sales made assume buyer has seen and approved actual sample(s). Exact color match cannot be guaranteed
- The use of any material by, or on behalf of the buyer, shall constitute acceptance of the material by the buyer.

CREDIT CARD POLICY:

- Credit card payments are not allowed for payments on accounts.
- All orders paying by credit card will be charged an additional 3.95% service fee whether card is presented or not.

ACCOUNTS POLICY:

- All credits will be applied to accounts towards balance on-hand or future purchases. No credit checks will be given.
- C.O.D orders must be paid with cash, credit card, certified check, or prior-approved check.
- All accounts are payable IN FULL within 30 days from the date of invoice. After 30 days, 1% interest will be charged per month (12% annually), calculated monthly on the balance at the end of the period. If any amount is past due on the account, the entire account is in default and (at the option of the seller), becomes due and payable immediately.

PALLET RETURN POLICY:

- Receipts will be given for pallets returned to any RCP yard. After careful inspection, customer accounts will be credited for returned pallets that are in good/re-usable condition. RCP reserves the right to deduct pallet costs based on pallet condition and does not guarantee any credit amount. Returned Pallet Credits will be applied to accounts for future purchases.

PARTIAL PALLET POLICY:

- A \$25 per pallet fee will be assessed for all partial pallet orders (any quantity other than original full pallet packaging).

MATERIAL RETURN POLICY:

- Materials ordered in excess of the Buyer's requirements, or in error, or otherwise, may not be returned without the written consent of the Seller.
- Returns after 30 days from delivery date are subject to a 25% restocking fee.
- Materials older than 60 days from delivery date cannot be returned.
- Materials being returned must have original pallet tag(s).
- Only full pallets of material will be accepted for return, no broken/partial pallets.
- Necessaries kits or components cannot be returned.
- All returns will be credited to the account.

DEFECTIVE MATERIAL POLICY:

- CLAIMS FOR DEFECTIVE MATERIAL MUST BE MADE WITHIN 3 DAYS OF DELIVERY. Defective material will be replaced at no charge or credited to accounts. Free replacement will be the extent of the Sellers' warranty. Any such defective material claim does not constitute justification for short pay or delayed payment. All other claims must be submitted within 30 days of purchase.
- Unsuitable or defective materials must be available for inspection by the Seller. If the Seller is unable to inspect defective material, buyer must submit photographs that clearly show material quality issues or damages. Buyer is required to submit pallet tags to verify the production lot/manufacturing date.
- Seller has final determination for the credit amount or the material quantity to be replaced.

SPECIAL RUN POLICY:

- \$550 set-up fee for standard colors
- Projects over 2,000 sq. ft. per mold set up, fee will be waved.
- Projects fewer than 500 sq. ft. will not be accepted.
- Special runs for colors not currently produce by RCP and affiliates will be quoted on a per job basis. Contact your RCP sales rep for a quote.
- Customer will receive project quote from sales with estimated completion date. Customer must use this quote sheet at time of ordering.
- 5-10% overage will be run on each project and is the responsibly of the customer to take all product produced.
- All special run orders must be shipped within ten business days of manufacture (after ten business days, additional fees will be assessed). Special run orders cannot be cancelled or returned. Customers who refuse delivery of any part of a special run will be invoiced for entire order.

CREDIT TERMS AND CONDITIONS

- Except as otherwise provided by written agreement subsequently executed by both Buyer and Seller, these Terms and Conditions, and the terms in Seller's invoices shall supersede the terms and conditions of Buyer's order (including, without limitation, any statement that Buyer's terms or conditions are to take precedence over any contrary provisions), and no prior or subsequent understanding, oral representation, agreement, term, condition, or trade custom at variance with or supplemental to these Terms and Conditions shall be binding on the Seller.
- Any extension of credit is issued pursuant to the information and financial representations made herein by said credit applicant and/or said guarantors.
- A faxed credit application will be deemed as original.
- Except as otherwise provided by written agreement subsequently executed by both Buyer and Seller, all amounts are due IN FULL net 30 days from date of invoice. Any such amounts not paid when due shall become delinquent and shall bear a late fee at the rate of one percent (1%) per month, or an ANNUAL PERCENTAGE RATE OF 12%.
- Rochester Concrete Products, LLC may decline further credit purchases if any portion of the account is past due.
- Returned checks are subject to a \$30.00 processing fee (or the maximum allowed by law in the state of acceptance).
- The privilege of making credit purchases will be terminated if there is any change in the applicant's ownership, management, or form of business organization unless Rochester Concrete Products, LLC is notified and agrees to such a change.
- Any amounts paid under this agreement by the Buyer to Rochester Concrete Products, LLC may be applied by Rochester Concrete Products, LLC to outstanding principal and interest as Rochester Concrete Products, LLC deems appropriate.
- Customer is responsible for all collection costs and legal fees if payment is not received pursuant to these Terms and Conditions.

GENERAL TERMS AND CONDITIONS OF SALE

These General Terms and Conditions of Sale (these "Terms and Conditions") will apply to the sale of goods and any (if any) applicable services (collectively, with any such services, being the "Goods") pursuant to any contract (a "Contract") to which these Terms and Conditions are made applicable. As used in these Terms and Conditions, "we," "us," "our" and similar terms refer to Rochester Concrete Products, LLC, and "Customer" means the party purchasing the Goods from us.

Alteration. No provision in these Terms and Conditions may be varied or waived except by a writing signed by us specifically referring to these Terms and Conditions and describing such variance or waiver. Our acceptance or acknowledgment of Customer's purchase order or any other document pertaining to the Goods, even if in writing and signed by us, will not be deemed an acceptance of any provision of Customer's purchase order or any other document that conflicts with or adds to these Terms and Conditions, absent a separate agreement in writing signed by us expressly acknowledging and agreeing to such provisions. Without limiting the generality of the foregoing, we object to any different or additional terms or conditions contained in any request for quotation, purchase order or other document of Customer, and no such terms will be effective or binding upon us unless we agree to such terms in a writing signed by one of our officers. In no event will our delivery of any Goods be an assent to any such terms proposed by Customer. Unless otherwise expressly stated in any applicable quotation or comparable document signed by us, we may revoke any quotation or other offer at any time prior to acceptance, and no such quotation or other offer will be valid for more than 30 days. After acceptance of an order, Customer may not cancel or terminate any Contract without our consent, except as provided herein or by applicable law.

Payment; Delivery. All prices are quoted and all payments will be made in U.S. Dollars. Customer will pay our invoices IN FULL on the terms stated in the applicable invoice, without set-off or counterclaim. Past due invoices will bear a late fee of 1.0% per month or, if less, the highest rate permitted by applicable law. Any stated shipment or delivery date is the date on which we in good faith believe the Goods will be shipped, but failure to ship on that date will not be a breach of the Contract, whether such Goods are in fact shipped before or after that date. All Goods are shipped Ex Works (Incoterms 2010) at our facilities, and costs of transportation and risk of loss during shipment will be borne by Customer. We may deliver any Goods hereunder in installments, in which case each installment will be treated as a separate sale hereunder and may be separately invoiced. Customer will pay all duties and sales, value-added, excise, use or other taxes arising in connection with any transaction (other than taxes based solely on our taxable income). Unless otherwise specified, Goods will be shipped in packaging we reasonably select.

Duty to Inspect. Customer will inspect all Goods promptly upon delivery and notify us promptly upon becoming aware of any non-conformity to the Contract. Except as stated regarding any applicable written warranty, we will have no liability regarding any such non-conformity unless such notice is given to us no later than (i) for a defect that could be determined by inspection upon delivery, the 30th day after delivery of such Goods, or (ii) for any other defect, the 30th day after such defect should reasonably have been discovered by Customer,

but in each event not later than the 60th day after delivery of the Goods to Customer. Shipments less than 5% over or under the quantity specified in the Contract will be deemed in conformance with the Contract. Goods will not be deemed non-conforming solely by reason of minor modifications or changes in materials from those specified in the Contract, so long as such modifications and changes do not materially and adversely affect the performance of the Goods. If the Goods do not conform to the Contract, our obligation will be limited to, at our election, supplying the missing Goods, replacing the relevant Goods, or refunding the purchase price paid for such Goods (but in all cases as otherwise may be limited in any other Paragraph of these Terms and Conditions or the Contract).

Security Interest. We reserve, and Customer hereby grants to us, a security interest in all Goods. That security interest secures all present and future obligations of Customer to us, including but not limited to the obligation to pay the price of the Goods. We may make any such filings as reasonably necessary to perfect such security interest (and Customer will cooperate promptly in all reasonable respects in connection therewith).

Our Warranty. Customer will ensure that any written warranty that we provide with the Goods is properly given to the end user of the Goods (whether by providing such warranty directly or causing Customer's contractors to do so).

Limited Warranty. We make no warranty of any nature whatsoever with respect to the Goods, other than any written, limited warranty that we may provide at the time we provide the Goods. If Customer discovers any breach of or similar creation of obligation under the warranty described above, Customer must notify us in writing thereof within 30 days after such discovery. Within a reasonable time following such notification, we will determine whether such warranty in fact applies and will, at our option, either (i) repair or replace the applicable Goods, (ii) remit to Customer the purchase price paid for such Goods, or (iii) take any other action consistent with the terms of such warranty. The foregoing warranties are exclusive. we make no other warranty, express or implied, including but not limited to any implied warranty of merchantability, non-infringement or fitness for a particular purpose. the remedies set forth in this paragraph are the exclusive remedy for any breach of or similar creation of obligation under warranty. The remedies set forth in this Paragraph will not be deemed to have failed of their essential purpose so long as we are willing and able to provide one of the applicable remedies set forth herein.

Limitations. Without limiting any other limitation of liability, in no event will we be liable for any incidental, indirect or consequential damages of any kind, whether for breach of any warranty, breach or repudiation of any other term or condition, negligence, strict liability, or otherwise. In no event will our aggregate liability to, through or on behalf of customer in any way related to this or any related transaction exceed the total amount paid to us under the applicable contract.

Force Majeure. We will not be liable for any failure to manufacture, deliver or provide, or for any delay in the manufacture, delivery or provision of, any Goods if such failure or delay is caused by act of God, fire, strike, blackout, labor difficulty, riot, inability to obtain raw materials, supplies or other goods or services, equipment, labor or transportation, governmental restrictions, public health nuisance, or similar cause over which we are unable to exercise adequate control. We may cancel any Contract by notice to Customer if we determine in good faith that any such cause makes performance of the Contract impossible or commercially impracticable for us.

Confidential Information. "Confidential Information" means information that you obtain from or regarding us regarding our products, business practices, customers, assets or other matters, excluding any information that is publicly available when provided or thereafter becomes publicly available, other than by reason of your breach hereof. You will (i) not use any Confidential Information other than for the performance of any Contract, (ii) not disclose Confidential Information, except to your employees and contractors requiring such information for the performance of any Contract, (iii) use your best efforts to prevent your employees, your contractors, and your contractors' employees from using or disclosing Confidential Information to any party, except as permitted by this Paragraph, and (iv) return all Confidential Information to us upon our request following completion or termination of any Contract. This Paragraph (and all related rights and remedies) will survive performance or termination of any Contract.

Miscellaneous. All rights and obligations under these Terms and Conditions and any Contract will be governed by the laws of the State of Minnesota (without regard to principles of conflicts of law). The headings herein are for convenience of reference only and will not affect any meaning or interpretation. The United Nations Convention on Contracts for the International Sale of Goods will not apply.

Customer hereby irrevocably submits to the exclusive jurisdiction of any court sitting in Hennepin county, Minnesota, in any proceeding arising out of or relating to the interactions between us and customer and to the respective court to which an appeal of the decisions of any such court may be taken, and customer agrees not to commence, or cooperate in or encourage the commencement of, any such proceeding, except in such a court. Customer hereby irrevocably waives, to the fullest extent it may do so, the defense of an inconvenient forum to the maintenance therein of such a proceeding. customer hereby agrees that a final judgment in any such proceeding will be conclusive and may be enforced in any jurisdiction by suit on the judgment or by any other manner provided by applicable law. Customer hereby expressly waives any right it may have to a jury trial in any such proceeding. no claim or action, regardless of form, arising out of the interactions between us and customer may be brought by or on behalf of customer more than one year after the cause of action has accrued (subject to any further applicable limitation). If any such legal action is brought, the prevailing party will be awarded reasonable attorneys' fees in addition to any other relief that may be granted.

LIMITED LIFETIME WARRANTY

Our products are designed to withstand the everyday use and abuse that you, time and Mother Nature can throw at them. Our limited lifetime warranty assures homeowners that what's meant to last, will last... and if it doesn't, we'll stand behind it.

IMPORTANT NOTICE: Read this entire RCP Limited Lifetime Warranty and Limitation of Liability ("Limited Warranty"). It is important that the warranted products be properly installed and maintained in order for them to function successfully throughout the duration of this Limited Warranty. Depending on the product's application, installation guides can be found at www.rockstercp.com. It is also important for your installer to carefully review the technical information, including specifications, for the chosen use of your RCP products as it may be the responsibility of the installer or design engineer to provide independent soil testing, quality assurance inspection, testing, and design services necessary to ensure a safe and functional application.

This Limited Warranty applies only to RCP products that are purchased and used as part of Rockwood Retaining Wall Systems installed in owner-occupied single-family homes within the United States, subject to the stated conditions and limitations. This Limited Warranty does not extend to any current or future products distributed, but not manufactured, by RCP. This Limited Warranty applies only to RCP's products and not to the system into which they may be placed. Nor does this Limited Warranty cover RCP products used in governmental, commercial, or multi-residential applications.

LIMITED LIFETIME WARRANTY FOR RCP PRODUCTS INSTALLED IN OWNER-OCCUPIED SINGLE-FAMILY HOMES AS A PART OF A ROCKWOOD WALL OR HARDSCAPE SYSTEM.

RCP warrants that its products will be free from defects for as long as you own your home. If RCP is given prompt notice of a defect, it shall, at its sole option: (1) repair or replace the defective product(s), or (2) refund the original purchase price of the defective product(s). This Limited Lifetime Warranty is provided only to the owner(s) of the home at the time of purchase and may not be assigned or transferred. In the event the owner(s) sells the home, this warranty automatically converts to a two-year limited warranty affording the same scope of protection and governed by the same conditions, disclaimers and limitations of this Limited Lifetime Warranty. If RCP elects to repair the defect, it shall be responsible for the labor to accomplish the repair. If RCP elects to replace the defective product(s), its obligation is to deliver suitable replacement product to owner's property.

LIMITATION OF LIABILITY

This Limited Warranty sets forth the maximum liability for our products. IN NO EVENT (INCLUDING WHERE THIS LIMITED WARRANTY IS DEEMED NOT TO APPLY TO THE SALE OR PRODUCT IN QUESTION) SHALL RCP, GLS INDUSTRIES, INC., OR ROCKWOOD RETAINING WALLS, INC. BE LIABLE FOR ANY INCIDENTAL, CONSEQUENTIAL OR SPECIAL DAMAGES RESULTING FROM THE SALE, INSTALLATION OR USE OF ANY RCP PRODUCTS. Some states do not allow the exclusion or limitation of incidental or consequential damages for consumers, so the above limitation or exclusion may not apply to you.

LIMITATION OF WARRANTY

RCP MAKES NO OTHER WARRANTIES, EXPRESS OR IMPLIED, INCLUDING ANY IMPLIED WARRANTIES FOR MERCHANTABILITY, FITNESS FOR A PARTICULAR PURPOSE OR OTHERWISE.

DISCLAIMER - WHAT THIS LIMITED WARRANTY DOES NOT COVER

RCP is not responsible for or makes no warranty as to:

1. Product failure, loss or damage due to:
 - Normal wear and tear;
 - Damage due to improper handling and repeated or extended contact with chemicals, such as de-icers;
 - Products improperly installed or maintained;
 - Acts of God;
 - Structural settlement, movement or vibration;
 - Products that have not been paid for in full.
2. Minor imperfections
 - Minor imperfections that do not affect the product's structural integrity;
 - Variations in product texture or color;
 - Efflorescence;
 - Minor imperfections in shape, appearance, or dimensions covered by ASTM C1372.

CONDITIONS OF WARRANTY - WHAT YOU MUST DO TO RECOVER UNDER THIS LIMITED WARRANTY

PROMPT NOTICE OF DEFECT:

Within the warranty period, you must promptly, and in no case more than one (1) year after any defect or other basis of a claim covered by this Limited Warranty is discovered or should have been discovered, notify RCP of the defect. Any claims otherwise covered by this Limited Warranty, but for which RCP did not receive notice of the defect within one (1) year from the time the problem first became known, shall be barred.



LIMITED WARRANTY CLAIM PROCEDURE

Claims under this Limited Warranty may be made in writing to RCP at 7200 Broadway Ave. N, Rochester, MN 55906.

Claims should include the following information:

1. Claimant's name, address and phone number, and the installation address (if different);
2. A description of the product, purchase price, date and location of purchase, and copies of invoices, if available;
3. A description of the defect(s) (photos are required); and
4. A brief summary of attempts made to address the concerns.

NO STATEMENT OF USEFUL LIFE

This Limited Warranty is not a statement of the useful life of any RCP products.

dms.us.51883281.01



Rochester Concrete Products is third-generation, family-owned business with mortarless concrete manufacturing experience dating back to 1914.

© 2024 Rochester Concrete Products. All Rights Reserved. All trademarks and registered trademarks are the property of their respective owners. Rockwood Retaining Walls products are made worldwide under license from Rockwood Retaining Walls, Inc. US and international patents issued and pending. 524

Printed in the USA.

www.rockstercp.com





www.rochestercp.com



Rochester
Concrete Products™

Corporate Office: 7200 Broadway Ave. N., Rochester, MN 55906 • Phone (507) 288-8850 • rochestercp.com

